



Rain screen Fast eners

Table of content

General information			
Features and Innovations	3	Self tapping fasteners	
Installation instruction	5	TDA-S-5.8	57
Explanation of levels	7	Self drilling fasteners	
		SX4-5.8	61
		SDA4-5.8	65
		SX3-5.5	69
		SX3-4.8	71
		TW-S-4.8	73
		TW-A4-4.8	75
		SCFW-S-5.0	77
		HTP-5.0	79
		SLA3-4.8	93
		SLA5-6.0	95
		Concealed fasteners	
		TUF-S	83
		TU-S	85
		TUC-S	87
		TD-A4	89
		Balcony fixing solution	
		BFS-NUT-5.0	97
		BFS-SLEEVE-5.0	99
		Accessories	
		FP-Sleeves	103
		DG	107
		Nosepiece	111
		Depth locator	113
		EPDM-Tape	117
		SDS drill bits	119
		Bits, sockets and drive bars	121
First level fixing			
Façade anchors			
SXR-FUS	15		
SXRL-FUS	17		
SXR-T	21		
SXRL-T	23		
Bolt anchor			
FAZ-II	27		
FXA	29		
Self drilling fasteners			
SX5-6.3	33		
Insulation anchor			
MDH	35		
MDD	37		
Second level fixing			
Self drilling fasteners			
SDA5-5.5	41		
SDA5-4.8	43		
SW3-4.8	45		
SDA2-4.8	47		
Third level fixing			
Rivets			
AP-5.0	51		
ASO-5.0	53		
SSO-5.0	55		

Features and Innovations

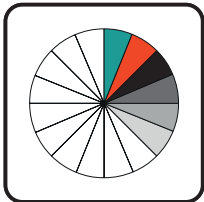

Paintable fasteners – all variants available

SFS offers a wide solution of coloured fasteners, wet or powder painted. The coating process produces a robust finish that is excellent against weathering, offering colour stability in exposed external applications.



Safe setting – resistant to unwinding and vibration

The geometry of the fastener, such as the cut-off thread-end and defined free-spin zone join forces to offer easy-to-use, highly secured fasteners – safe against over-torquing. The result is a vibration-resistant connection that will not unwind.



Fire approved – reliable and secure

These products are produced from non-flammable material (class A1) according to EN 13501-1, and tested for their fire resistance to class R30–R120 according to EN 13501-2.

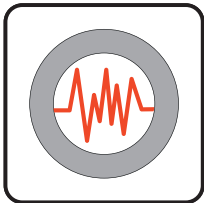

Seismic approved – high physical life

Seismic approved products have been developed for category C1 and/or C2 according to Eurocode EN 1992-4 and ensure high durability and service life.

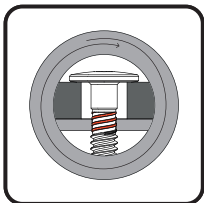

Reduced thread – safe and tension-free installation

The reduced thread allows the fastener to be over-torqued, resulting in a tension-free installation. Within the defined clamping range, it is ensured that the connection does not rattle.

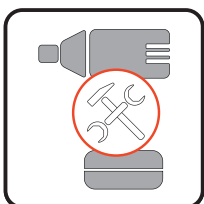

Impact drivers can be used – ergonomical installation

The geometry of the fastener allows the use of an impact gun machine. These machines are ergonomic to use as there is no torque on the wrist. Also the machines are usually smaller than regular drills and can therefore be used in hard to reach places.

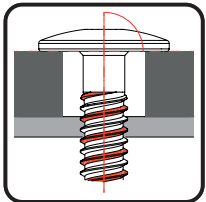

Double-start thread – ideal alignment

The double-start thread ensures ideal alignment of the fastener with respect to the panel. Furthermore it prevents the fastener from unscrewing due to expansion and contraction.

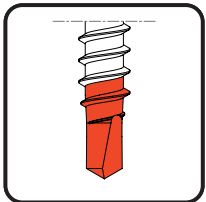

Bi-Metal – high corrosion resistance

High corrosion resistance as the material in the clamping area is made of austenitic stainless steel. At the same time, it is possible to drill into steel thanks to the carbon steel drill tip.

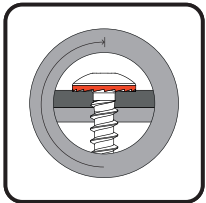

Underhead ribs – protection against overwinding

The underhead ribs act as a kind of brake pad and thus reduce the risk of overwinding.



Centered fastening – for a long-lasting façade

The fastener is installed concentric to the pre-drilled cladding panel. This allows the thermal expansion to be fully utilised. In order to achieve this, the recommended tools and the corresponding installation guidelines must be observed.

Installation instructions

Installation of self drilling fasteners

General information

- Install self-drilling fasteners in general at 1'200–2'000 rpm
- Recommended drilling pressure for self-drilling fasteners: 150–300 N
- Use clean tool, which fits exactly for installation of painted fasteners

Use of impact wrench

- Is only permitted for products where it is specifically indicated

Installation of rivets

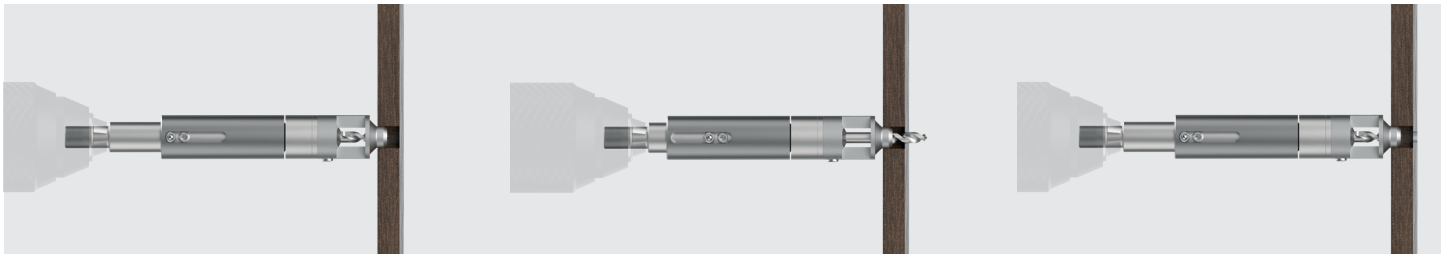

- The rivet needs to be installed centrally to the pre-drilled cladding panel
- For pre-drilling the subframe the use of the DG (Drilling Gauge) is recommended

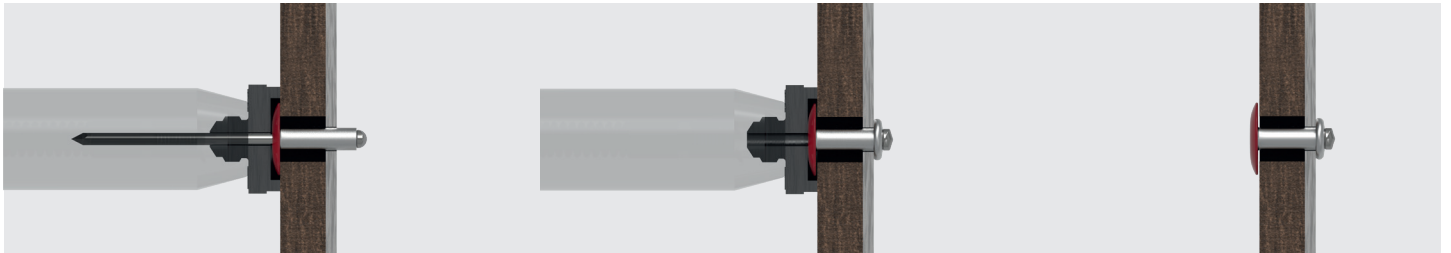

- The panels must be able to move freely, therefore the rivets must not be tightened too much
- To ensure a constraint-free installation, the use of a mechanical rivet tool equipped with the appropriate nosepiece is mandatory

Explanation of levels

First level fixing

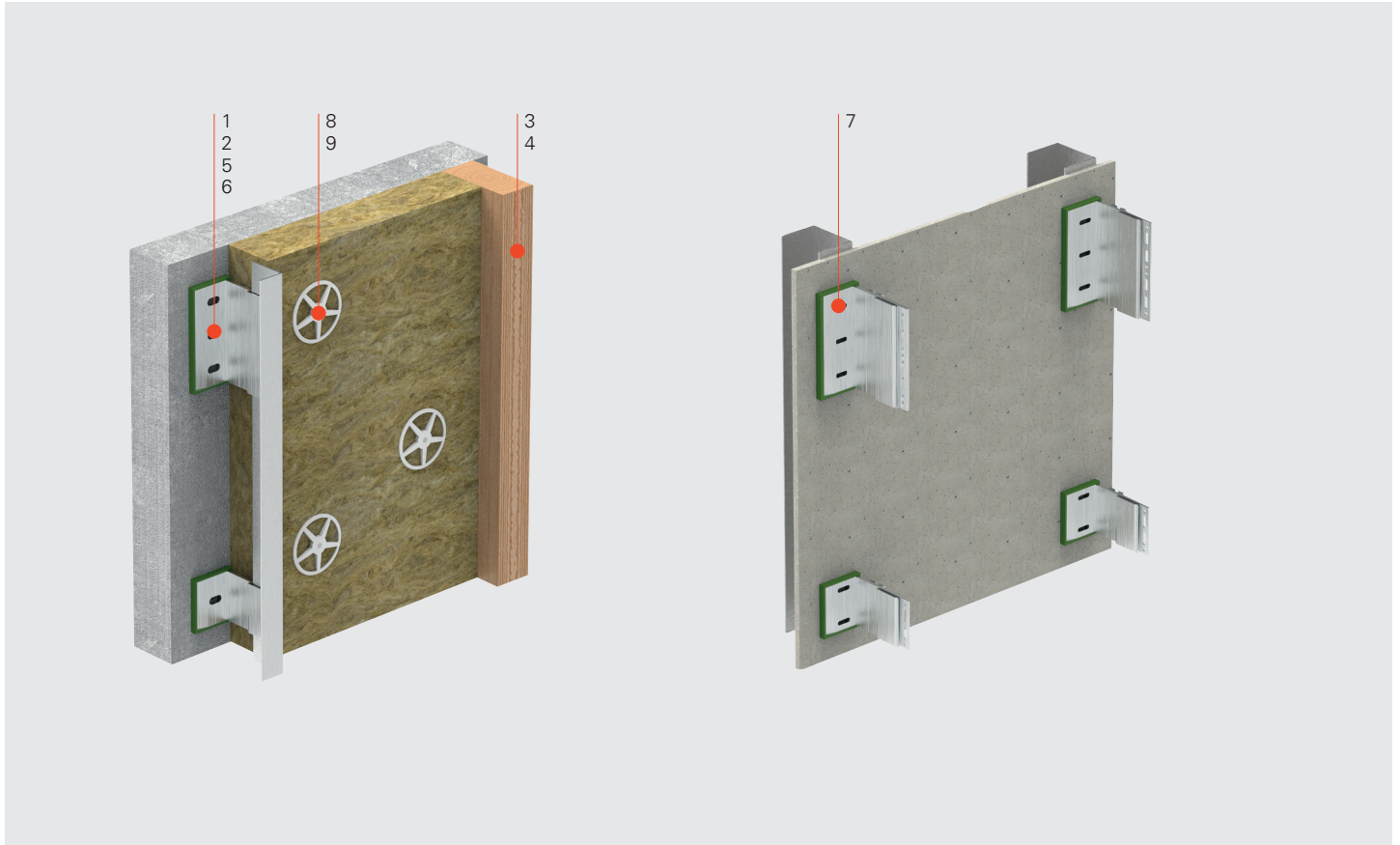

Façade anchor			Page	●	Self driller			Page	●	Insulation fixing			Page	●
T	A4	SXR-FUS	15	1	A2	SX5-6.3	33	7	PP	MDH	35	8		
T	A4	SXRL-FUS	17	2					PA	MDD	37	9		
T	A4	SXR-T	21	3										
T	A4	SXRL-T	23	4										
T	A4	FAZ-II	27	5										
T	A4	FXA	29	6										

- A2 Austenitic stainless steel A2
- A4 Austenitic stainless steel A4
- T Carbon steel
- PP Polypropylen
- PA Polyamide
- E EPDM
- A Aluminium

Explanation of levels

Second level fixing

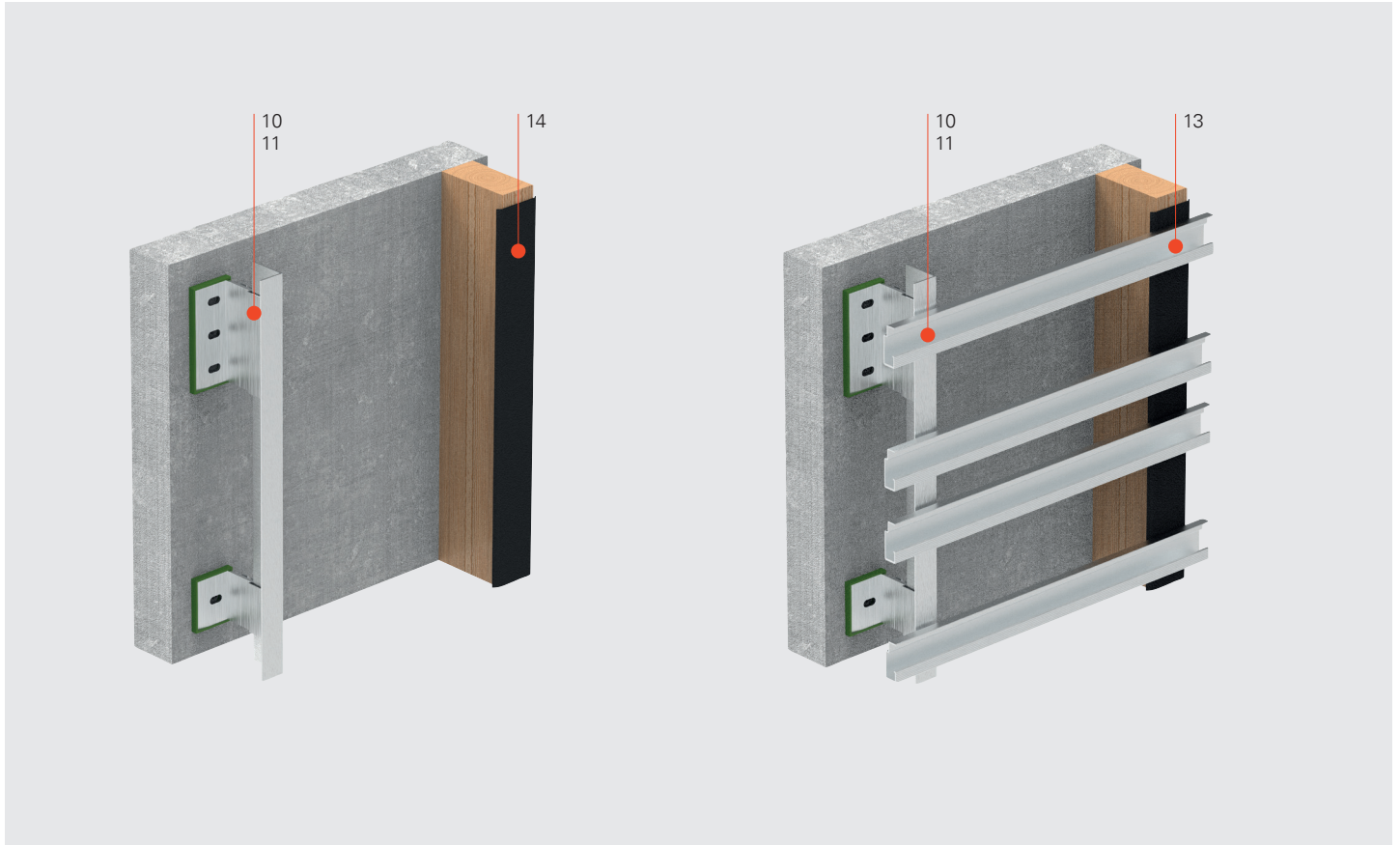

Self driller	Page	●	Accessories	Page	●		Page	●		Page	●
A4 SDA5-5.5	41	10	E EPDM-Tape	117	14						
A4 SDA5-4.8	43	11									
A2 SW3-4.8	45	13									

- A2 Austenitic stainless steel A2
- A4 Austenitic stainless steel A4
- T Carbon steel
- PP Polypropylen
- PA Polyamide
- E EPDM
- A Aluminium

Explanation of levels

Second level fixing

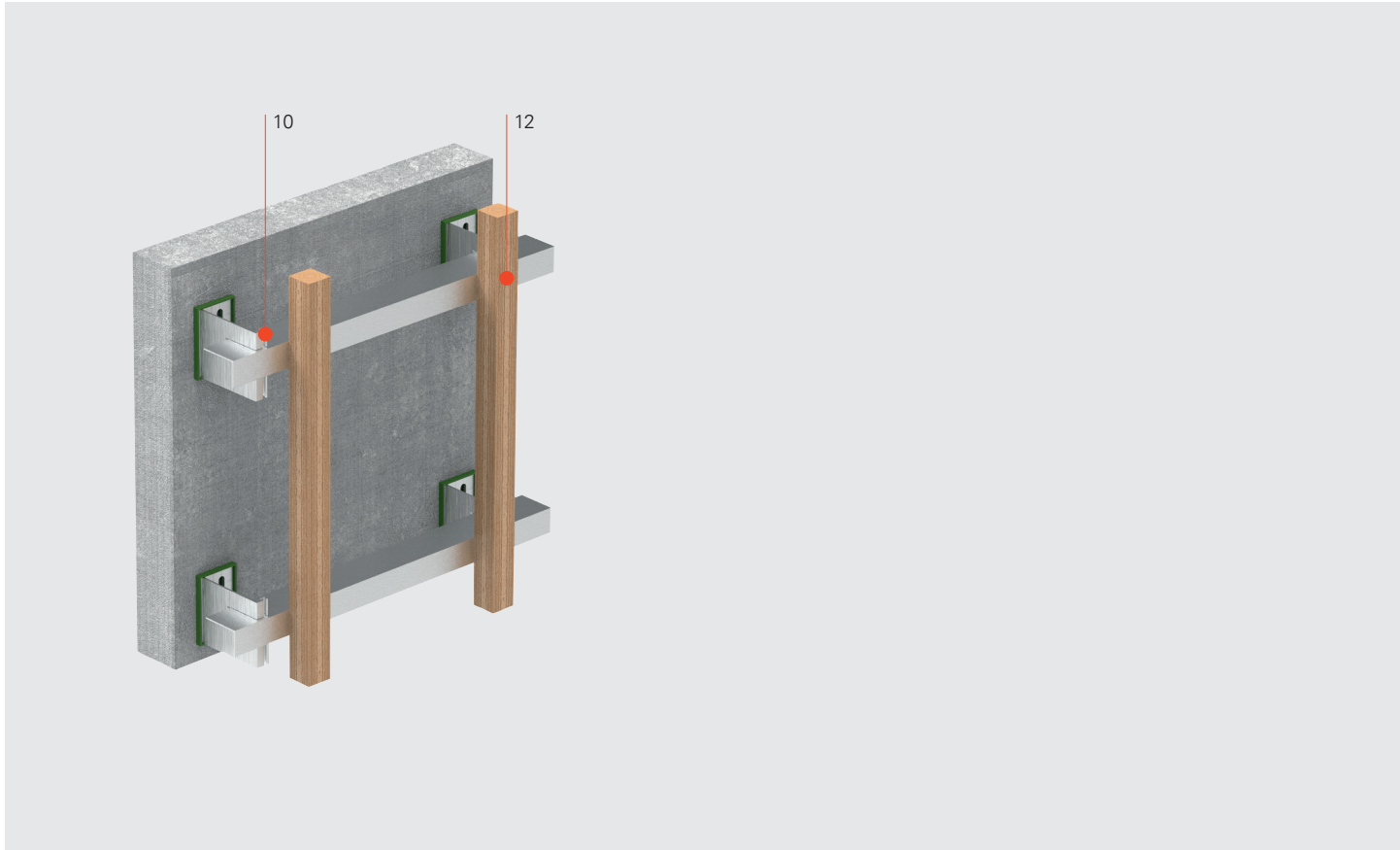

Self driller	Page	●	Page	●	Page	●	Page	●
A4 SDA5-5.5	41	10						
A2 SDA2-4.8	47	12						

- A2 Austenitic stainless steel A2
- A4 Austenitic stainless steel A4
- T Carbon steel
- PP Polypropylen
- PA Polyamide
- E EPDM
- A Aluminium

Explanation of levels

Third level fixing Visible fixing onto timber subframe

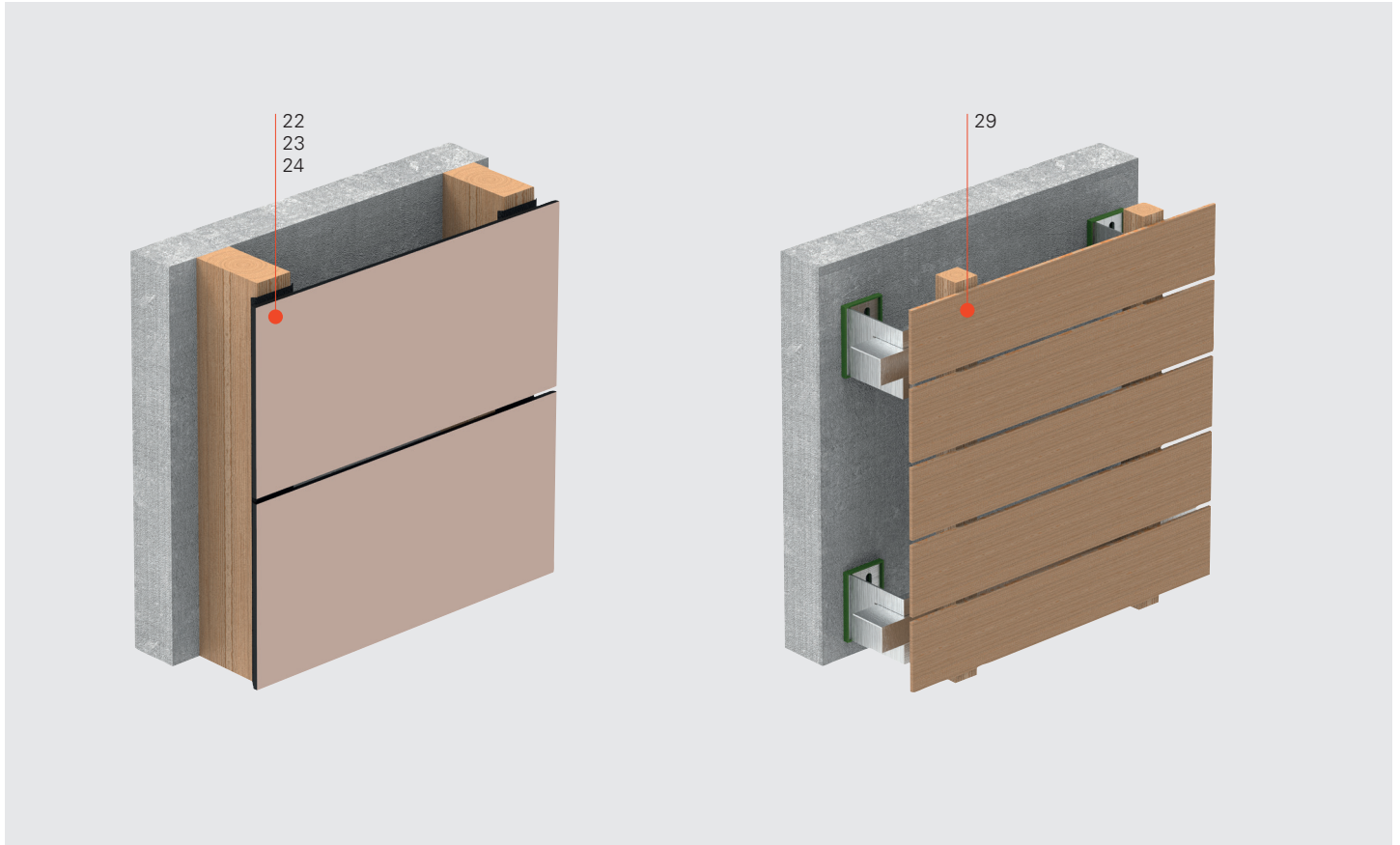

Self driller	Page	●	Page	●	Page	●	Page	●
A2 TW-S-4.8	73	22						
A4 TW-A4-4.8	75	23						
A2 SCFW-S-5.0	77	24						
A2 HTP-5.0	79	29						

- A2 Austenitic stainless steel A2
- A4 Austenitic stainless steel A4
- T Carbon steel
- PP Polypropylen
- PA Polyamide
- E EPDM
- A Aluminium

Explanation of levels

Third level fixing Visible fixing onto metal subframe

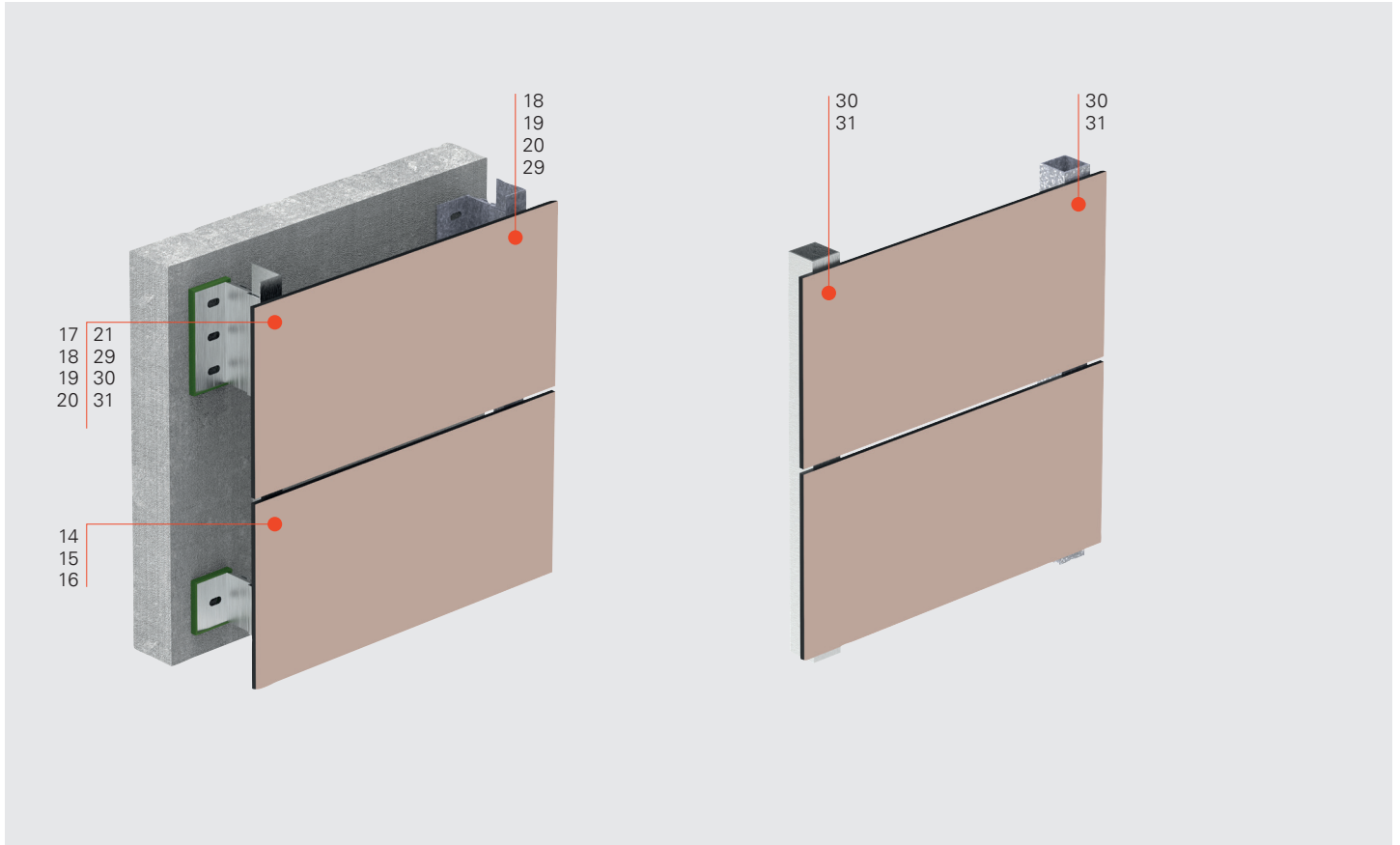

Self driller on Aluminium			Self driller on steel			Self tapper			Rivets		
	Page	●		Page	●		Page	●		Page	●
A4 SDA4-5.8	65	17	A4 SX4-5.8	61	18	A2 TDA-S-5.8	57	29	A AP-5.0	51	14
A4 SX4-5.8	61	18	A2 A4 SX3-5.5	69	19	A2 BFS-NUT-5.0	97	30	A ASO-5.0	53	15
A2 A4 SX3-5.5	69	19	A2 SX3-4.8	71	20	A2 BFS-SLEEVE-5.0	99	31	A4 SSO-5.0	55	16
A2 SX3-4.8	71	20									
A4 SLA3-4.8	93	21									

A2 Austenitic stainless steel A2
 A4 Austenitic stainless steel A4
 T Carbon steel
 PP Polypropylen
 PA Polyamide
E EPDM
A Aluminium

Explanation of levels

Third level fixing Concealed fixing

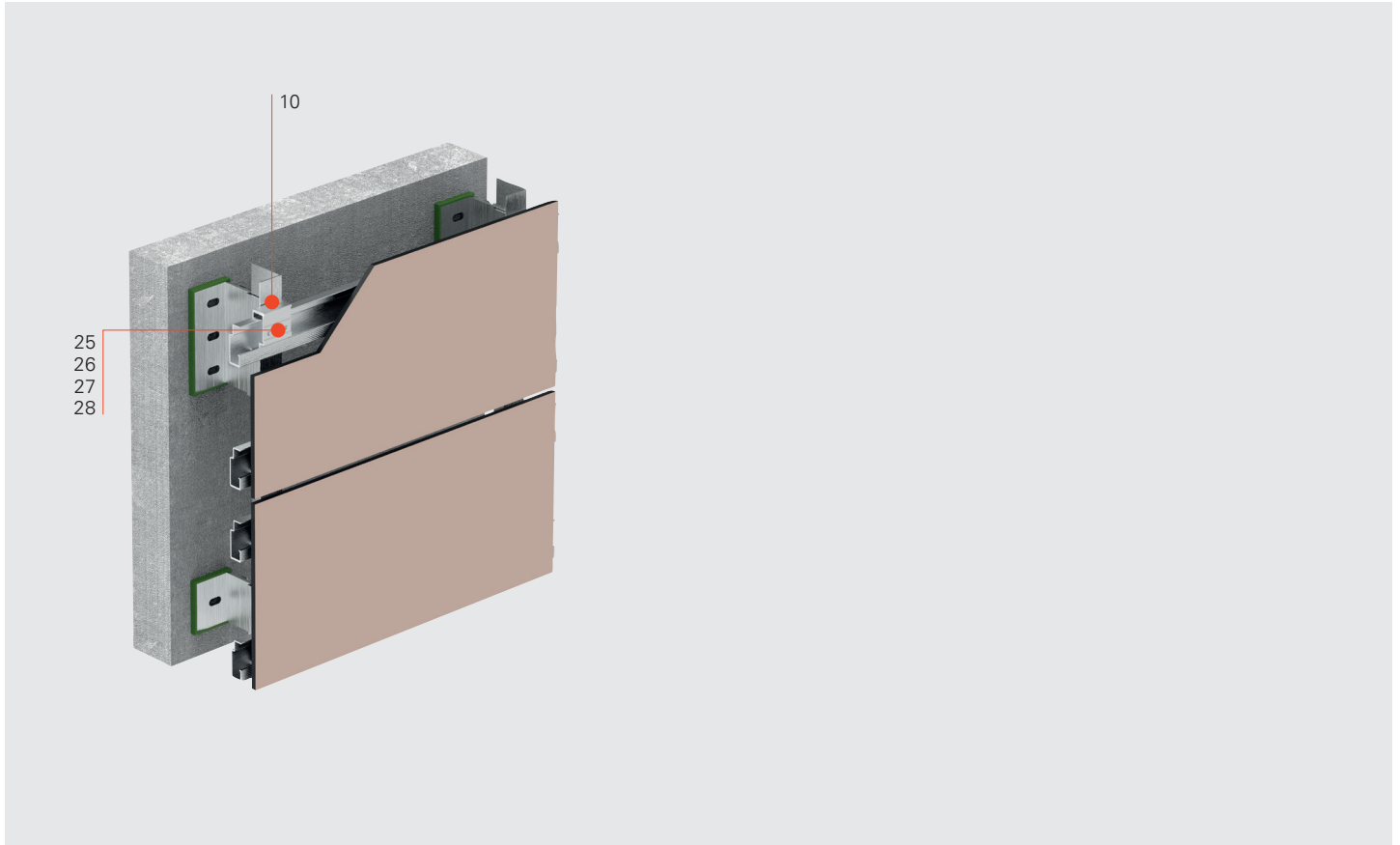

Self driller		Page	●	Blind fasteners		Page	●			Page	●			Page	●
A2	SDA5-5.5	41	10	A4	TUF-S	83	25								
				A4	TU-S	85	26								
				A4	TUC-S	87	27								
				A4	TD-A4	89	28								

- A2 Austenitic stainless steel A2
- A4 Austenitic stainless steel A4
- T Carbon steel
- PP Polypropylen
- PA Polyamide
- E EPDM
- A Aluminium



Nando's

Nando's
Christmas
Burger



First level fixing

SXR-FUS

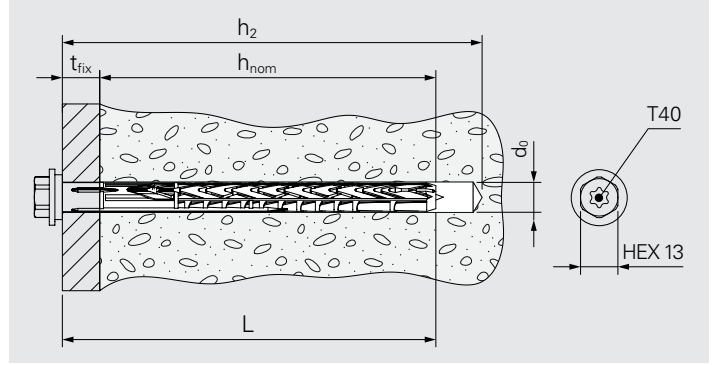
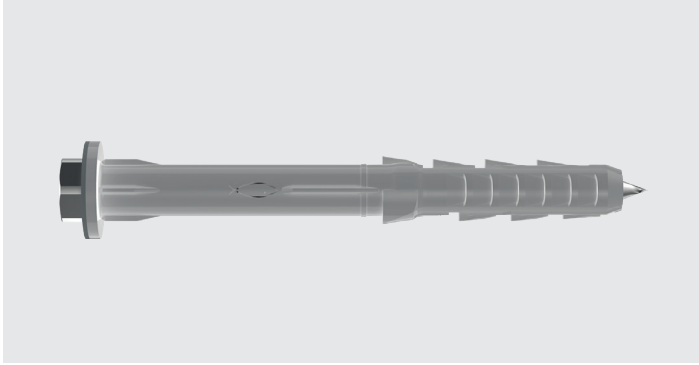

Application

Fastening of a pre-punched bracket onto substrate

Component 1 (t_I)

Bracket

Component 2 (t_{II})

Substrate

Fastener material

Body: Polyamide PA6

Fastener: galvanized steel or austenitic stainless steel A4

Approvals



Features and Benefits

- Anchor suitable for installation of a bracket onto various substrates
- Geometry of the expansion element enables the use in many substrates
- Short expansion element requires only a small drilling depth
- Distinctive rotation lock increases the ease of assembly and provides additional safety

Documentation

Approval document (ETA) | Declaration of performance (DoP)

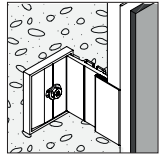

Frame anchor in polyamide and galvanized steel onto cladding panel

Product code	PU	L	t _{fix}	h _{nom}	h ₂	d ₀	
SXR-10×60-FUS	50	60	10	50	70	10	1333512
SXR-10×80-FUS		80	30		90		1333569
SXR-10×100-FUS		100	50		110		1333570
SXR-10×120-FUS		120	70		130		1333571
SXR-10×140-FUS		140	90		150		1333572
SXR-10×160-FUS		160	110		170		1333573
SXR-10×200-FUS		200	150		210		1333576
SXR-10×230-FUS		230	180		240		1333577

Frame anchor in polyamide and A4 onto cladding panel

Product code	PU	L	t _{fix}	h _{nom}	h ₂	d ₀	
SXR-10×60-FUS-A4	50	60	10	50	70	10	1333579
SXR-10×140-FUS-A4		140	90		150		1333580

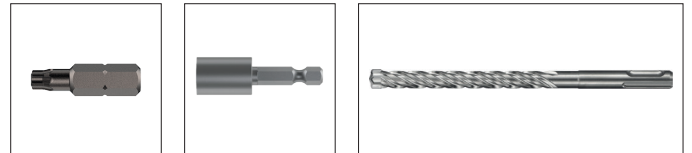

Accessories/Ancillaries

Product code	PU	L	Drive	Head drive	D	WL	FL	
T40-25-HEX 1/4"	1	25	1/4"	T40	-	-	-	769474
E313-1/4"-50		50		HEX13				508029
SDS-10×215/150-4C		215	-	-				10

SXRL-FUS

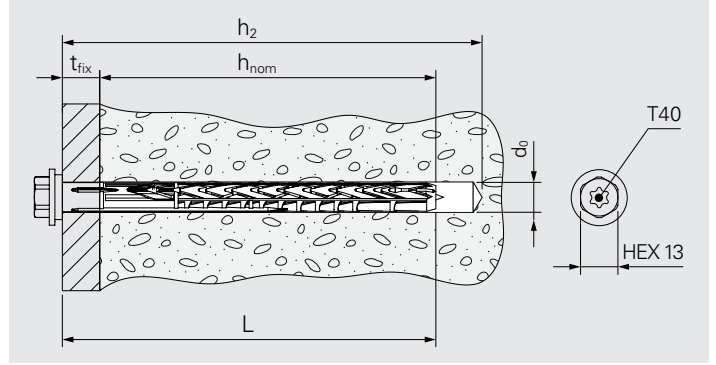
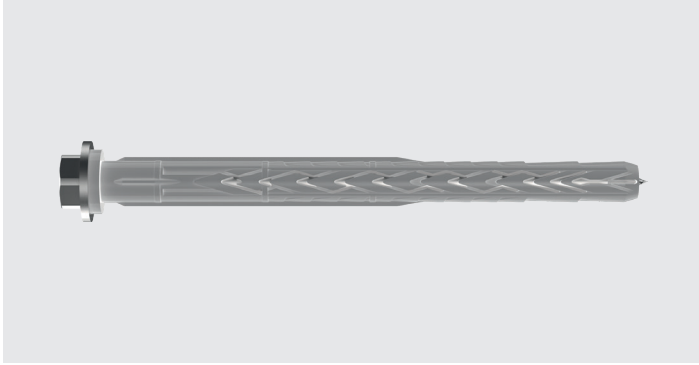

Application

Fastening of a pre-punched bracket onto substrate

Component 1 (t_1)

Bracket

Component 2 (t_2)

Substrate

Fastener material

Body: Polyamide PA6

Fastener: galvanized steel or austenitic stainless steel A4

Approvals



Features and Benefits

- Anchor suitable for installation of a bracket onto various substrates
- Versatile product thanks to the long expansion element
- Retention forces are evenly distributed in the drill hole thanks to the geometry of the plug
- Ribs prevent plug rotation during installation

Documentation

Approval document (ETA) | Declaration of performance (DoP)

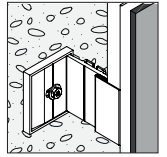

Frame anchor in polyamide and galvanized steel onto substrate

Product code	PU	L	max.t _{fix}			h ₂	d ₀	
			h _{nom} ≥ 50	h _{nom} ≥ 70	h _{nom} ≥ 90			
SXRL-10×60-FUS	50	60	10	–	–	70	10	1657909
SXRL-10×80-FUS		80	30	10	–	90		1492203
SXRL-10×100-FUS		100	50	30	10	110		1494422
SXRL-10×120-FUS		120	70	50	30	130		1711416
SXRL-10×160 FUS		160	110	90	70	170		1667834

Frame anchor in polyamide and A4 onto substrate

Product code	PU	L	max.t _{fix}			h ₂	d ₀	
			h _{nom} ≥ 50	h _{nom} ≥ 70	h _{nom} ≥ 90			
SXRL-10×60-FUS-A4	50	60	10	–	–	70	10	1744493
SXRL-10×80-FUS-A4		80	30	10	–	90		1568224
SXRL-10×100-FUS-A4		100	50	30	10	110		1697684
SXRL-10×120-FUS-A4		120	70	50	30	130		1756596
SXRL-10×140-FUS-A4		140	90	70	50	150		1756597

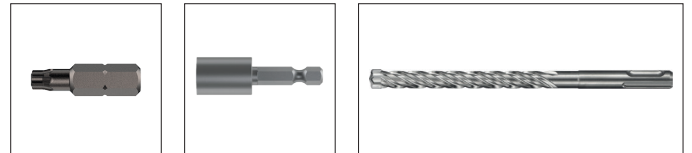

Accessories/Ancillaries

Product code	PU	L	Drive	Head drive	D	WL	FL	
T40-25-HEX ¼"	1	25	¼"	T40	–	–	–	769474
E313-¼"-50		50		HEX13				508029
SDS-10×215/150-4C		215	–	–				10

Installation instruction for SXR-FUS and SXRL-FUS

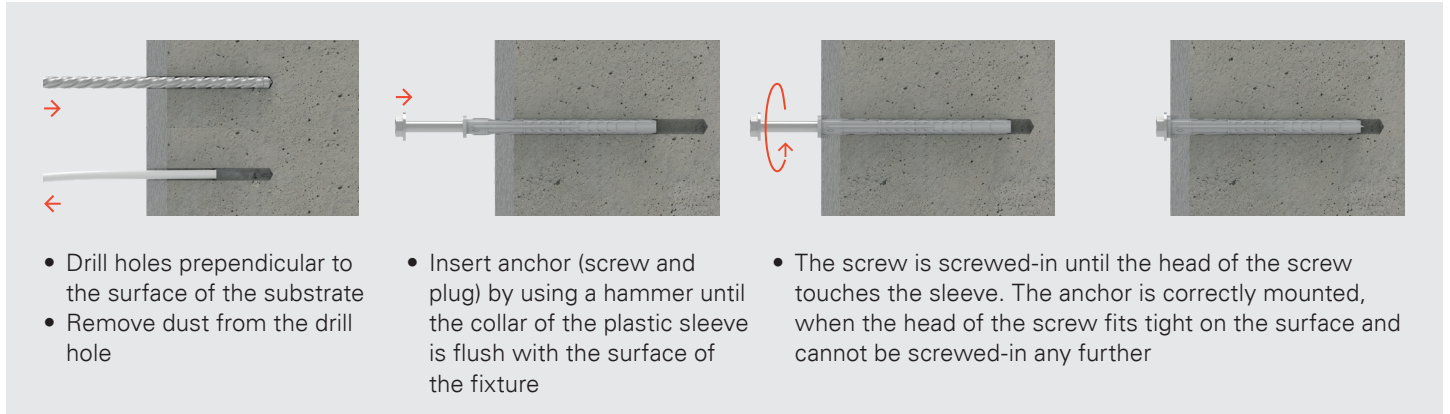

The image shows a four-step installation process for SXR-FUS and SXRL-FUS anchors. Step 1: A drill bit is used to create a hole in a concrete substrate, with a red arrow pointing right. A white plastic sleeve and a screw are shown below the hole, with a red arrow pointing left. Step 2: The white plastic sleeve is inserted into the hole, with a red arrow pointing right. Step 3: The screw is inserted into the sleeve, with a red arrow pointing right. Step 4: The screw is tightened into the sleeve, with a red circular arrow indicating rotation. The final image shows the anchor fully installed and flush with the surface.

- Drill holes perpendicular to the surface of the substrate
- Remove dust from the drill hole
- Insert anchor (screw and plug) by using a hammer until the collar of the plastic sleeve is flush with the surface of the fixture
- The screw is screwed-in until the head of the screw touches the sleeve. The anchor is correctly mounted, when the head of the screw fits tight on the surface and cannot be screwed-in any further

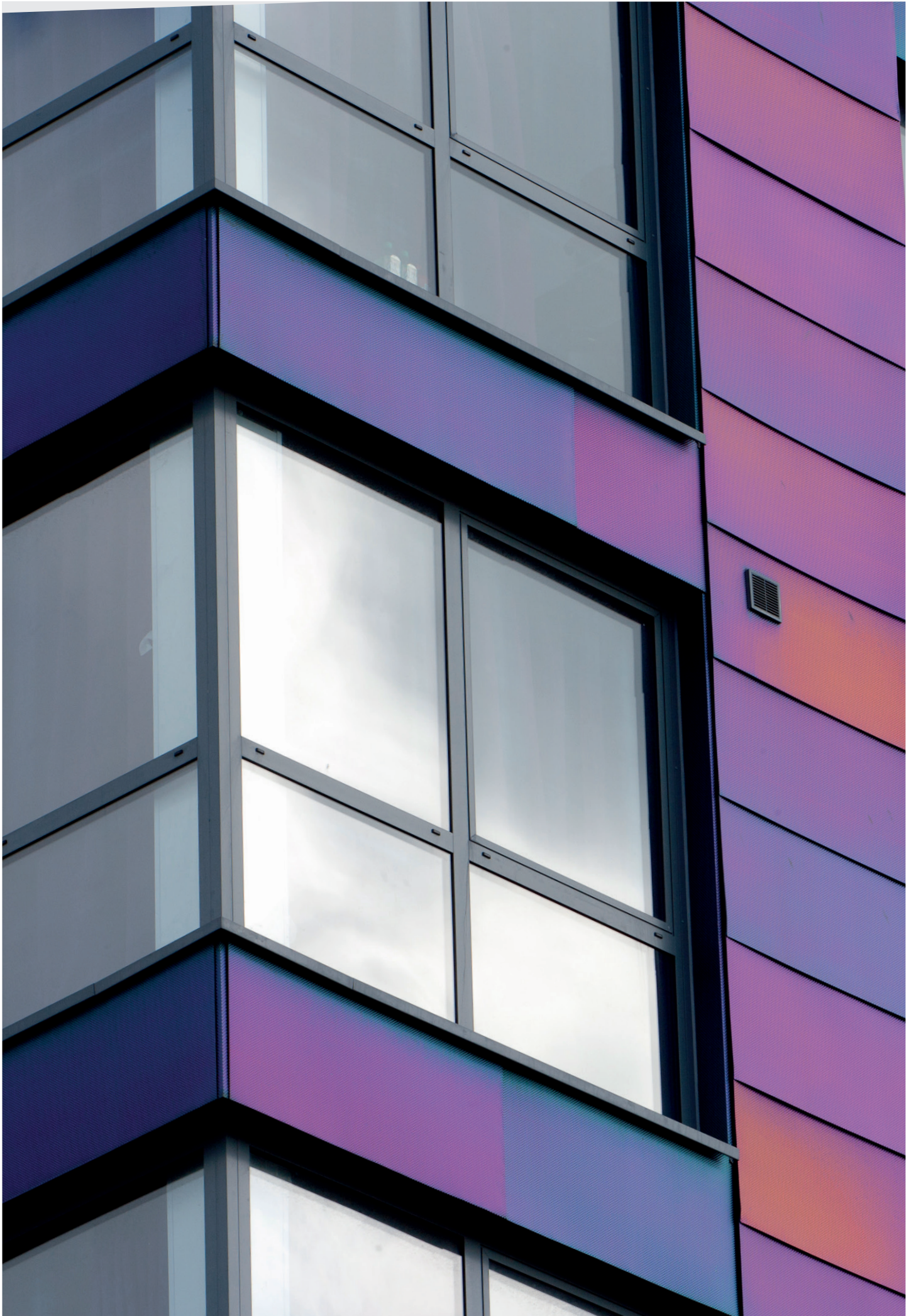

SXR-T

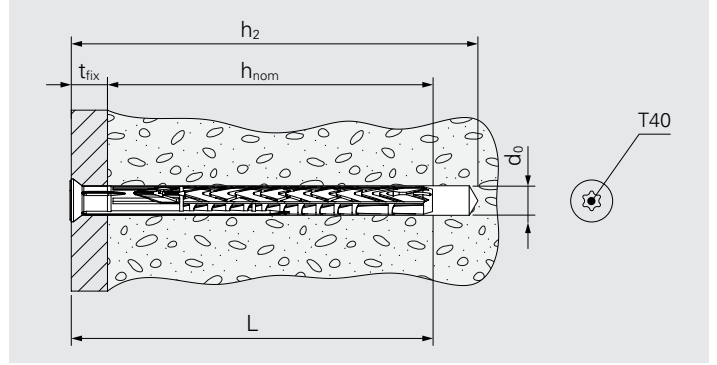
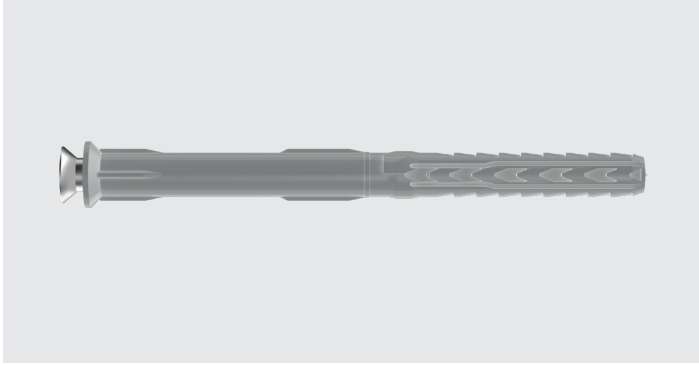

Application

Fastening of a timber batten onto substrate

Component 1 (t_I)

Timber batten

Component 2 (t_{II})

Substrate

Fastener material

Body: Polyamide PA6
Fastener: galvanized steel

Approvals

CE₀₇
ETA-07/0121

Features and Benefits

- Anchor suitable for installation of a timber batten onto various substrates
- Geometry of the expansion element enables the use in many substrates
- Short expansion element requires only a small drilling depth
- Distinctive rotation lock increases the ease of assembly and provides additional safety

Documentation

Approval document (ETA) | Declaration of performance (DoP)



Frame anchor in polyamide and galvanized steel onto substrate

Product code	PU	L	t _{fix}	h _{nom}	h ₂	d ₀	
SXR-10×80-T	50	80	30	50	90	10	1333511
SXR-10×100-T		100	50		110		1333558
SXR-10×120-T		120	70		130		1333559
SXR-10×140-T		140	90		150		1333562
SXR-10×160-T		160	110		170		1333564
SXR-10×180-T		180	130		190		1333565
SXR-10×200-T		200	150		210		1333566
SXR-10×230-T		230	180		240		1333567
SXR-10×260-T		260	210		270		1333568

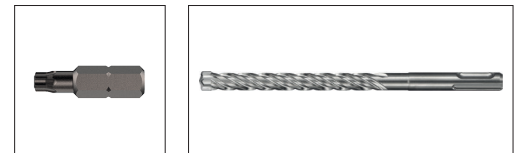

Accessories/Ancillaries

Product code	PU	L	Drive	Head drive	D	WL	FL	
T40-25-HEX $\frac{1}{4}$ "	1	25	$\frac{1}{4}$ "	T40	–	–	–	769474
SDS-10×215/150-4C	1	215	–	–	10	150	150	1487586

SXRL-T

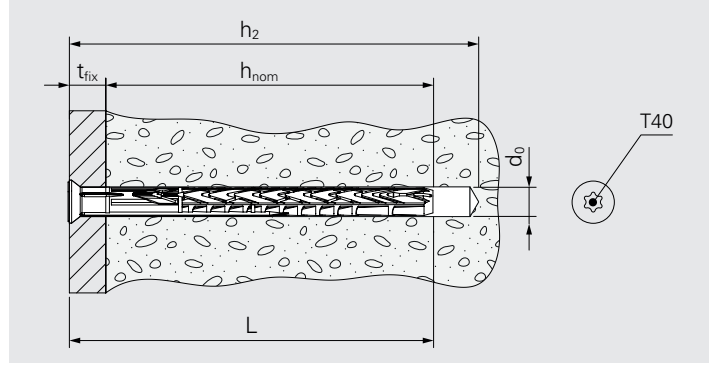
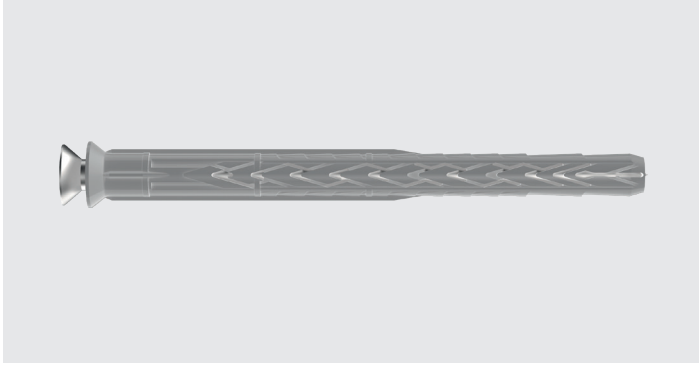

Application

Fastening of a timber batten onto substrate

Component 1 (t_i)

Timber batten

Component 2 (t_{ii})

Substrate

Fastener material

Body: Polyamide PA6

Fastener: galvanized steel

Approvals

CE₀₇
ETA-07/0121

Features and Benefits

- Anchor suitable for installation of a timber batten onto various substrates
- Versatile product thanks to the long expansion element
- Retention forces are evenly distributed in the drill hole thanks to the geometry of the plug
- Ribs prevent plug rotation during installation

Documentation

Approval document (ETA) | Declaration of performance (DoP)

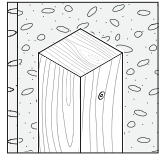

Frame anchor in polyamide and galvanized steel onto substrate

Product code	PU	L	max. t _{fix}			h ₂	d ₀	
			h _{nom} ≥ 50	h _{nom} ≥ 70	h _{nom} ≥ 90			
SXRL-10×80-T	25	80	30	10	–	90	10	1562247
SXRL-10×100-T	50	100	50	30	10	110		1716144
SXRL-10×120-T		120	70	50	30	130		1743966
SXRL-10×140-T		140	90	70	50	150		1376693

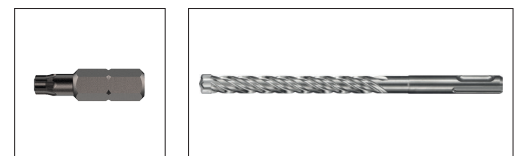

Accessories/Ancillaries

Product code	PU	L	Drive	Head drive	D	WL	FL	
T40-25-HEX¼"	1	25	¼"	T40	–	–	–	769474
SDS-10×215/150-4C		215	–	–	10	150	150	1487586

Installation instruction for SXR-T and SXRL-T

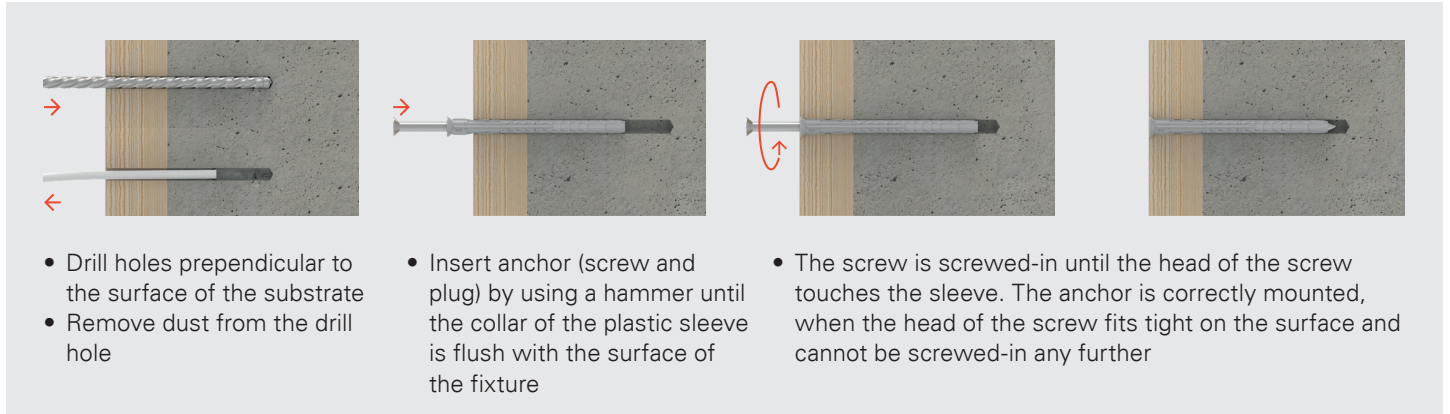

The image shows a four-step installation process for SXR-T and SXRL-T anchors. Each step is illustrated with a photograph of the anchor being installed into a concrete substrate, with a wooden fixture placed over it. Red arrows indicate the direction of action: drilling, insertion, and tightening.

- Drill holes perpendicular to the surface of the substrate
- Remove dust from the drill hole
- Insert anchor (screw and plug) by using a hammer until the collar of the plastic sleeve is flush with the surface of the fixture
- The screw is screwed-in until the head of the screw touches the sleeve. The anchor is correctly mounted, when the head of the screw fits tight on the surface and cannot be screwed-in any further

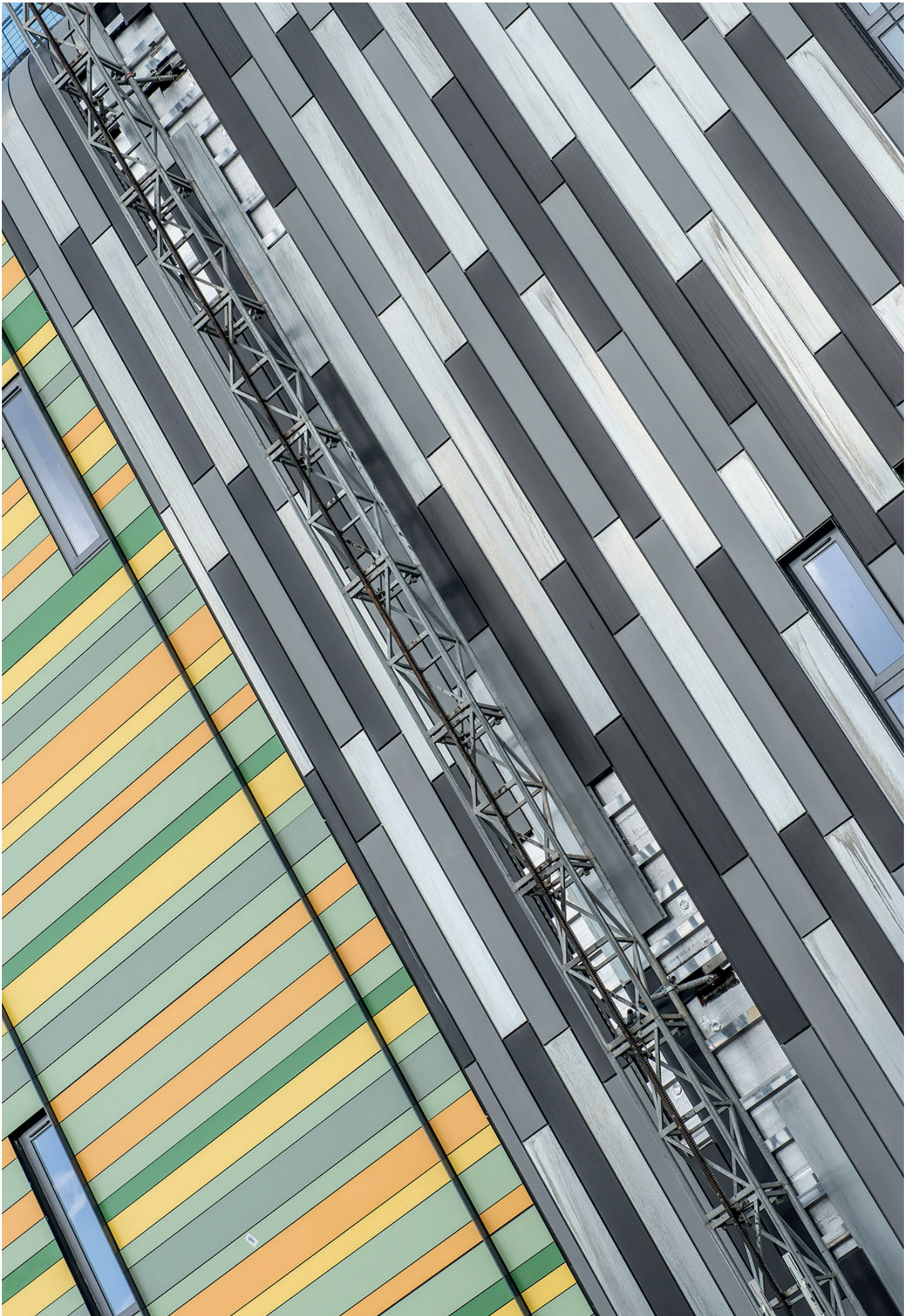

FAZ-II

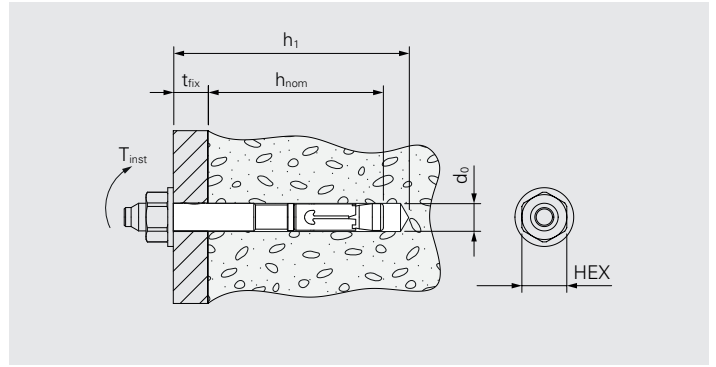
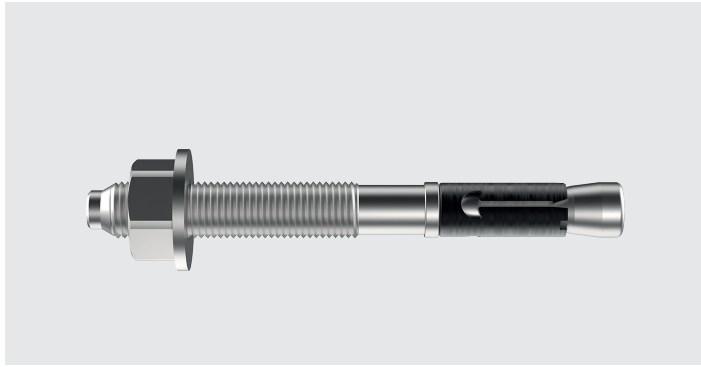

Application

Fastening of a bracket onto substrate

Component 1 (t_i)

Bracket

Component 2 (t_{ii})

Substrate

Fastener material

Fastener: galvanized steel or austenitic stainless steel A4

Approvals



Features and Benefits

- Anchor suitable for installation of a bracket onto various substrates
- Approved for cracked and non-cracked concrete C20/25 to C50/60
- Approved for use in seismic category C1
- Reduced anchorage depths save time and costs during drilling
- Simple assembly saves time as well as wear and tear

Documentation

Approval document (ETA) | Declaration of performance (DoP)

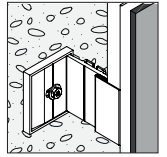

Bolt anchor in galvanized steel onto substrate

Product code	PU	d ₀	min. h _{nom}	max. t _{fix}	h ₁	Drive	T _{inst} [Nm]	
FAZ-II-8/10	50	8	45	10	h _{nom} +5	HEX13	20	1333426
FAZ-II-10/10		10	52			HEX17	45	1526930

Bolt anchor in A4 onto substrate

Product code	PU	d ₀	min. h _{nom}	max. t _{fix}	h ₁	Drive	T _{inst} [Nm]	
FAZ-II-8/10-A4	50	8	45	10	h _{nom} +5	HEX 13	20	1333466
FAZ-II-10/10-A4		10	52			HEX 17	45	1333468



Accessories/Ancillaries

Product code	PU	Drive	Head drive	D	L	WL	FL	
SDS-8×215/150-4C	1	-	-	8	215	150	150	1487585
SDS-10×215/150-4C				10				1487586
E313-¼"-50		¼"	HEX13	-	-	-	-	508029

FXA

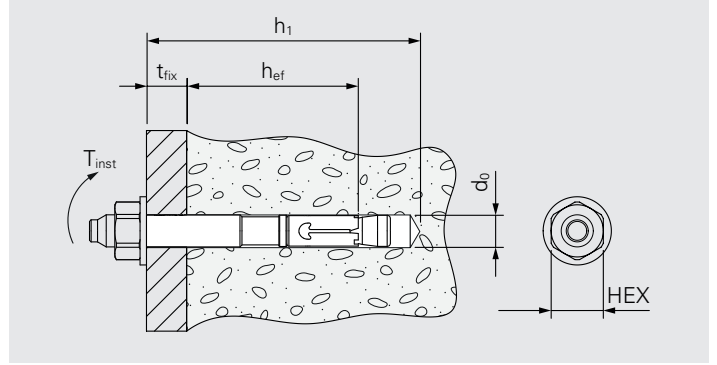
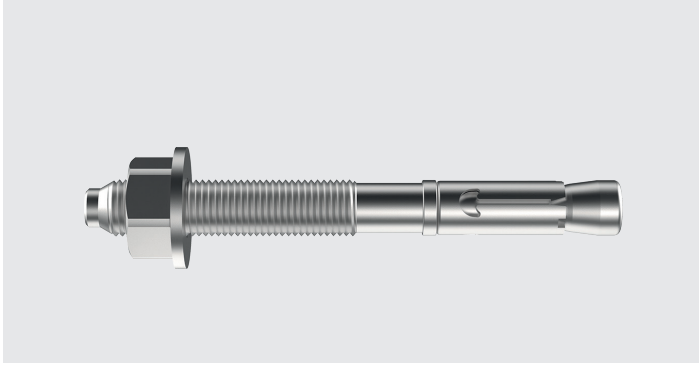

Application

Fastening of a bracket onto substrate

Component 1 (t_i)

Bracket

Component 2 (t_{ii})

Substrate

Fastener material

Fastener: galvanized steel or austenitic stainless steel A4

Approvals

CE₁₃
ETA-13/0772

Features and Benefits

- Anchor suitable for installation of a bracket onto various substrates
- Approved for non-cracked concrete C20/25 to C50/60
- Simple assembly saves time as well as wear and tear

Documentation

Approval document (ETA) | Declaration of performance (DoP)

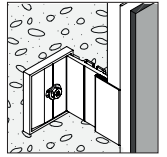

Bolt anchor in galvanized steel onto substrate

Product code	PU	d ₀	min. h _{ef}	max. t _{fix}	min. h ₁	Drive	T _{inst} [Nm]	
FXA-8/5×66	50	8	40	5	56	HEX 13	15	1427314
FXA-8/10×71				10				1427315
FXA-10/10×86		10	50	68	HEX 17	30	1681093	

Bolt anchor in A4 onto substrate

Product code	PU	d ₀	min. h _{ef}	max. t _{fix}	min. h ₁	Drive	T _{inst} [Nm]	
FXA-8/10X71-A4	50	8	40	10	56	HEX 13	10	1526931
FXA-10/10X86-A4		10	50		68	HEX 17	20	1681094



Accessories/Ancillaries

Product code	PU	Drive	Head drive	D	L	WL	FL	
SDS-8×215/150-4C	1	-	-	8	215	150	150	1487585
SDS-10×215/150-4C				10				1487586
E313-¼"-50		¼"	HEX13	-	-	-	-	508029

Installation instruction for FAZ-II and FXA

The installation process is shown in four sequential images:

- Drilling:** A drill bit is shown drilling a hole into a concrete substrate. Red arrows indicate the direction of the drill bit.
- Insertion:** The anchor (screw and plug) is inserted into the drilled hole. A red arrow points to the right, indicating the direction of insertion.
- Tightening:** The anchor is tightened into the hole. A red circular arrow and the label T_{inst} indicate the application of installation torque.
- Final State:** The anchor is fully installed and flush with the surface of the substrate.

- Drill holes perpendicular to the surface of the substrate
- Remove dust from the drill hole
- Insert anchor (screw and plug) by using a hammer until the collar of the plastic sleeve is flush with the surface of the fixture
- The anchor is screwed-in until the prescribed installation torque T_{inst} is reached.

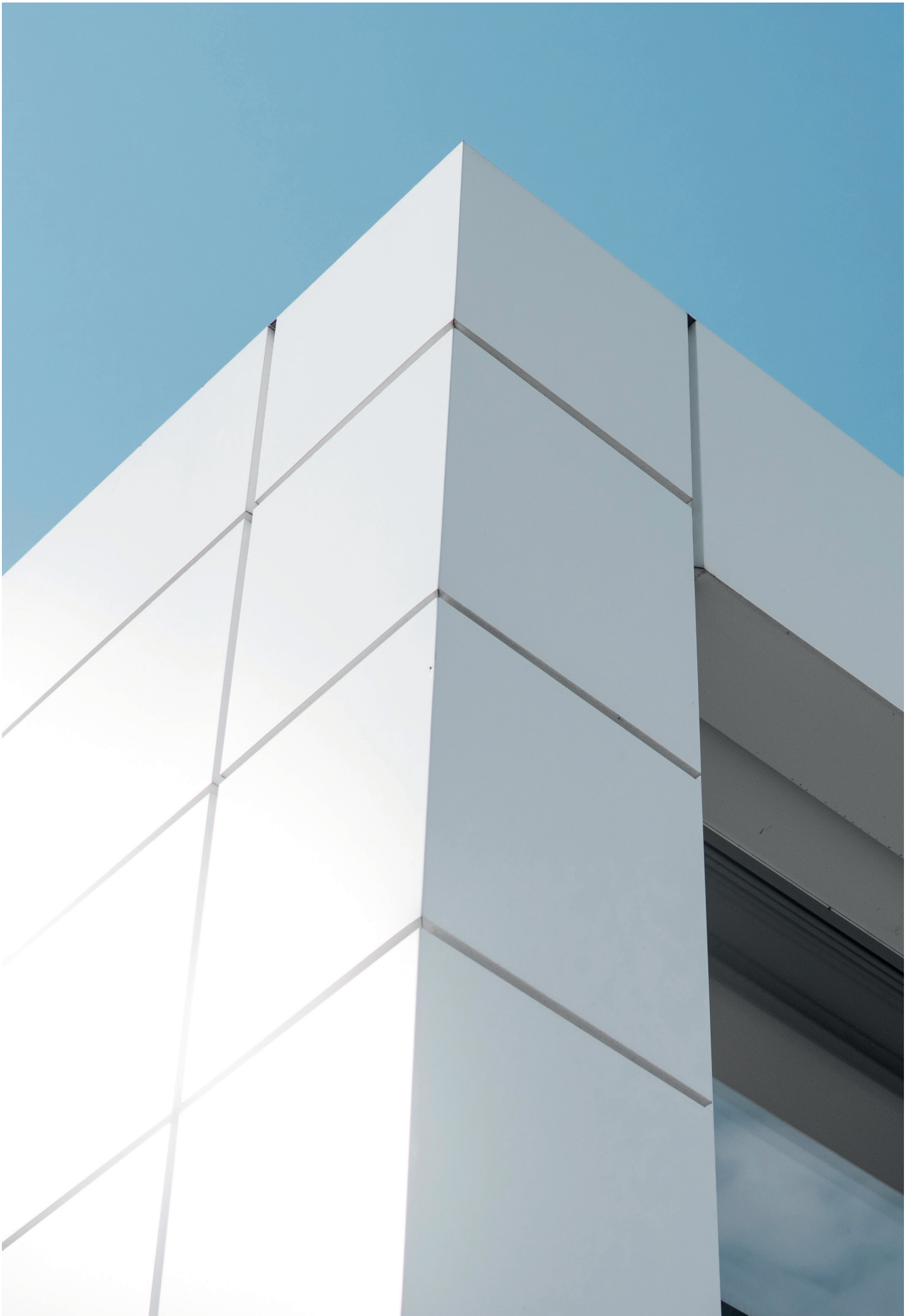

SX5-6.3

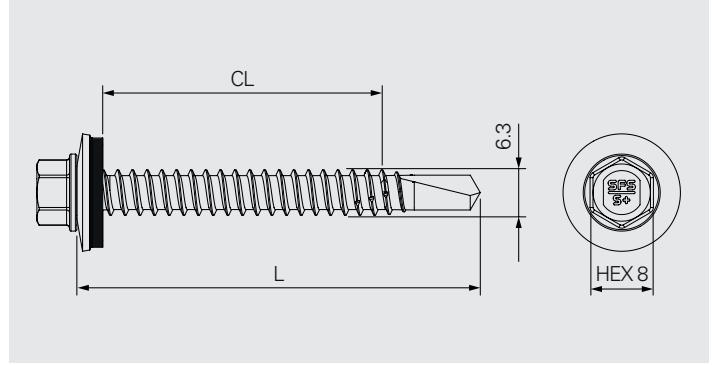

Application

Fastening of bracket through cement bonded particle board to steel stud

Component 1 (t_I)

Bracket	
Pre-drill Ø	6.5
Cement bonded	
Particle board	≤16.0

Component 2 (t_{II})

Steel	1.2–3.0
-------	---------

Fastener material

Fastener: Austenitic stainless steel A4, case hardened drill point
 Washer: Austenitic stainless steel A4 with EPDM-seal

Approvals



Features and Benefits

- Self drilling fastener suitable for fastening bracket through cement bonded particle board sheeting onto steel stud
- Penetrates board and substructure in one operation without pre-drilling
- Versatile applications possible given by the large clamping range
- Optical recognition of whether fastener is properly tightened thanks to the washer

Documentation

Approval document (ETA) | Declaration of performance (DoP)

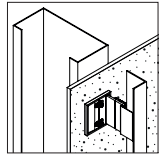

Fastener in A4 onto steel

Product code	PU	L	CL	
SX5/36-S16/A4-6,3x55-A4	250	55	0-36	1570614



Accessories/Ancillaries

Product code	PU	L	Drive	Head drive	
E308-1/4"-50	1	50	1/4"	HEX8	1646160

MDH

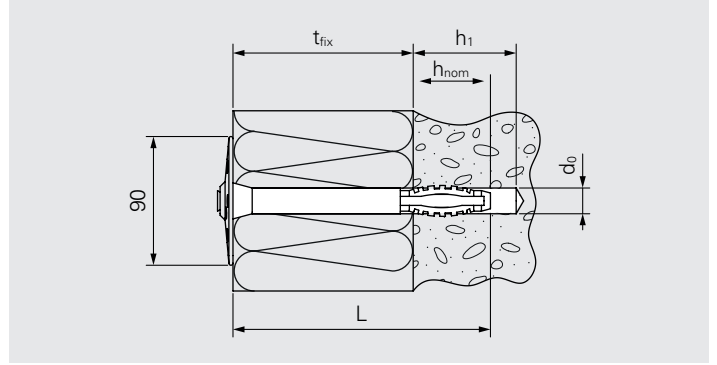
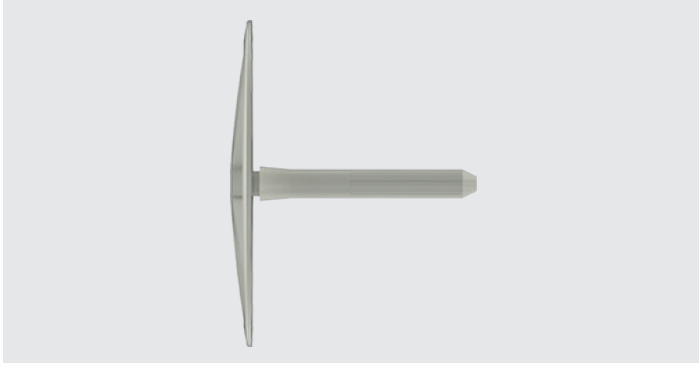

Application

Mechanical fixing of soft mineral fibre-mats on walls

Component 1 (t_i)

Soft mineral fibre-mats

Component 2 (t_{ii})

Concrete
Bricks
Other high-density materials

Fastener material

Polypropylene

Approvals

–

Features and Benefits

- Insulation fixing suitable for installation of insulation material onto high-density substrate material
- Contact pressure by deformation of the longitudinal ribs fix the plug in the drill hole
- Temperature resistance from -40° to $+70^{\circ}$ Celsius

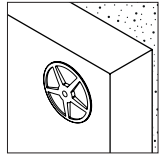

Insulation anchor onto substrate

Product code	PU	L	d ₀	min. h ₁	min. h _{nom}	max. t _{fix}	
MDH-8×60	250	60	8	25	20	40	523835
MDH-8×80		80				60	523836
MDH-8×100		100				80	523837
MDH-8×120		120				100	523838
MDH-8×140		140				120	1234497
MDH-8×160		160				140	1234498
MDH-8×180*		180				35	30
MDH-8×200*	200	170	523843				
MDH-8×220*	220	190	523844				
MDH-8×240*	240	210	523845				

*consists of two parts

Installation instruction

- Drill a pilot hole
- Set plug until head lies flush on insulation
- Use a hammer for installation
- MDH has to be hammered precisely onto insulation

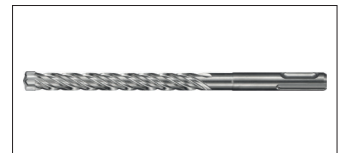

Accessories/Ancillaries

Product code	PU	L	D	WL	FL	
SDS-8×215/150-4C	1	215	8	150	150	1487585

MDD

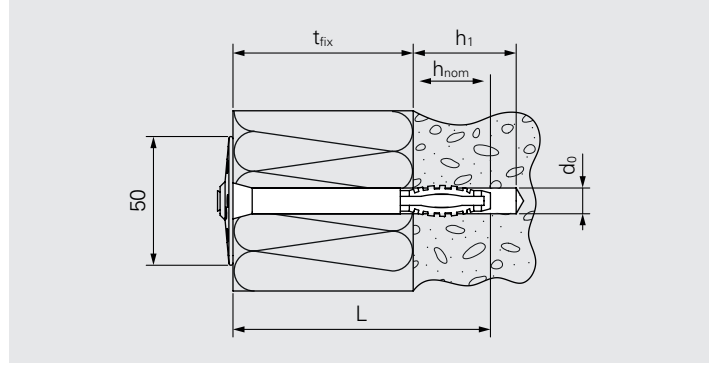

Application

Mechanical fixing of hard board insulation plates on walls

Component 1 (t_i)

Hardboard insulation plates

Component 2 (t_{ii})

Concrete
Bricks
Other high-density materials

Fastener material

Plug: Polyamide
Nail: Polyamide

Approvals

–

Features and Benefits

- Insulation fixing suitable for installation of insulation material onto high-density substrate material
- Spreading of the plug leads to anchoring
- Temperature resistance from -40° to $+70^{\circ}$ Celsius

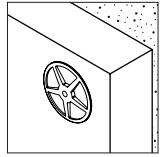

Insulation anchor onto substrate

Product code	PU	L	d ₀	min. h ₁	min. h _{nom}	max. t _{fix}	
MDD-10×70	250	70	10	40	30	40	974804
MDD-10×90		90				60	974805
MDD-10×110		110				80	974806
MDD-10×130		130				100	974807
MDD-10×160		160				130	1403024
MDD-10×180		180				150	1419658
MDD-10×210		210				180	974811

Installation instruction

- Drill a pilot hole
- Set plug until head lies flush on insulation
- Drive-in the nail with a hammer
- Nail has to be hammered precisely into the head

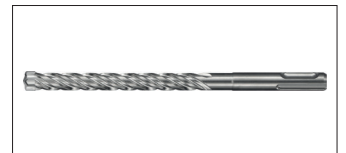

Accessories/Ancillaries

Product code	PU	L	D	WL	FL	
SDS-10×215/150-4C	1	215	10	150	150	1487586





Second level fixing

SDA5-5.5

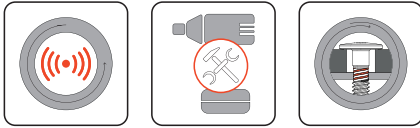
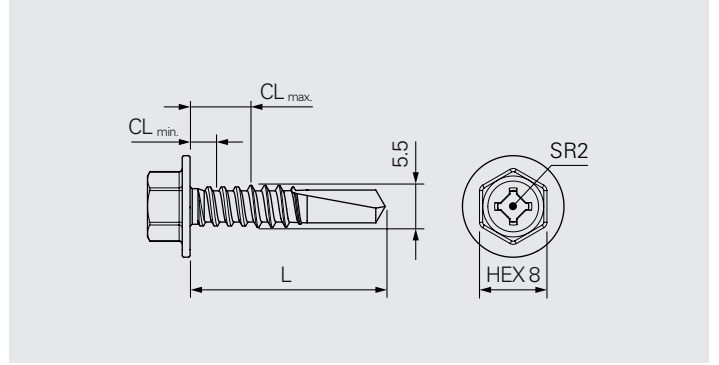
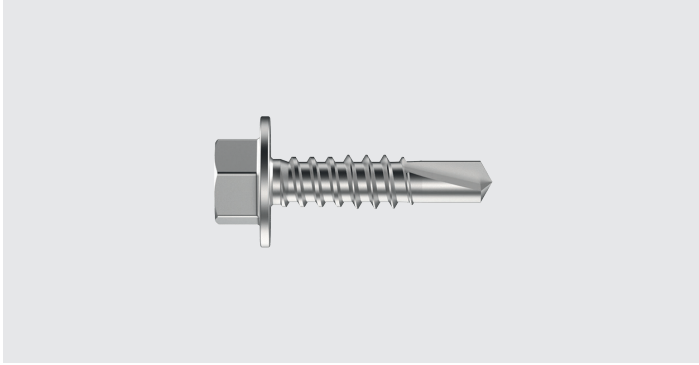

Application

- Fastening of pre-punched bracket to aluminium rail
- Fastening of aluminium rail to aluminium rail
- Fastening of a hanger to an aluminium rail

Component 1 (t _I)		Component 2 (t _{II})		Σ _{max} t _I + t _{II}
Aluminium	≥2.0	Aluminium	1.5–4.0	5.0
Aluminium	≥2.0	Aluminium	1.5–4.0	–
Pre-drill Ø	5.2–5.5			
Steel	≥1.5	Aluminium	1.5–4.0	–
Pre-drill Ø	5.5			

Fastener material

Austenitic stainless steel A2/A4

Approvals



Features and Benefits

- Self drilling fastener suitable for installation of metal bracket or aluminium profile onto aluminium structure
- Both impact gun and regular drill gun machine can be used for installation
- Secured against rattling given by reduced thread and perfectly matched clamping length
- No torque control required given by reduced thread
- Secured against unwinding given by reduced thread
- Connecting components are pulled together during setting process given by reduced thread
- Fastener can be over-tightened

Documentation

Approval document (ETA) | Declaration of performance (DoP)

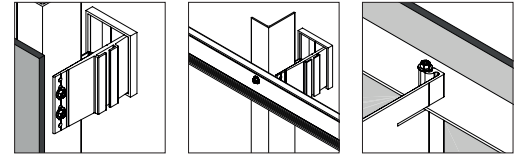

Fastener in A4 onto aluminium

Product code	PU	L	CL	
SDA5/3,5-6-H13-S4-5,5x20	500	20	3.5-6.0	1499657
SDA5/3,5-8-H13-S4-5,5x22		22	3.5-8.0	1507572
SDA5/25-28-H13-S4-5,5x45		45	25.0-28.0	1645134

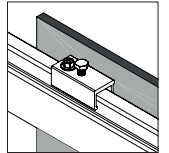

Fastener in A2 onto aluminium

Product code	PU	L	CL	
SDA5/3,5-16-H13-S-5,5x30	100	30	3.5-16	1692307

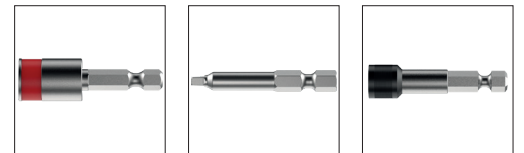

Accessories/Ancillaries

Product code	PU	L	Drive	Head drive	
E308-¼"-50	1	50	¼"	HEX8	1646160
SR2-25-HEX¼"	10	-		SR2	1146918
Bit holder ZA¼"	1	58		¼"	1162306

SDA5-4.8

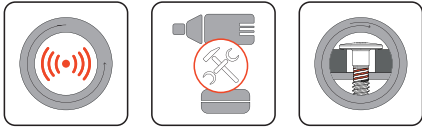
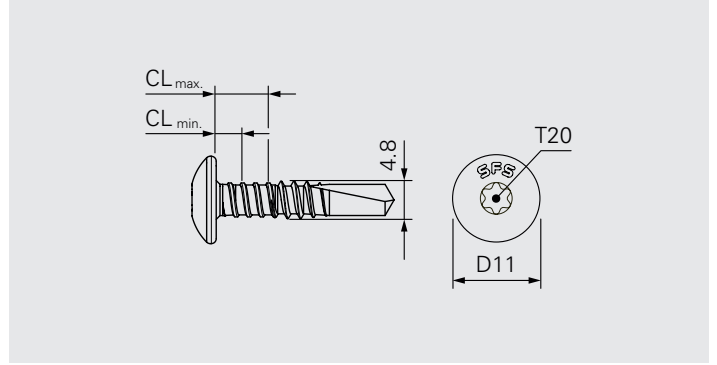

Application

Fastening of pre-punched bracket to aluminium rail
 Fastening of aluminium rail to aluminium rail

Component 1 (t _I)		Component 2 (t _{II})		$\Sigma_{\max} t_I + t_{II}$
Aluminium	≥2.0	Aluminium	1.5–4.0	5.0
Aluminium	≥2.0	Aluminium	1.5–4.0	–
Pre-drill Ø	5.0			
Steel	≥1.5	Aluminium	1.5–4.0	–
Pre-drill Ø	5.0			

Fastener material

Austenitic stainless steel A4

Approvals

–

Features and Benefits

- Self drilling fastener suitable for installation of metal bracket or aluminium profile onto aluminium structure
- Both impact gun and regular drill gun machine can be used for installation
- Secured against rattling given by reduced thread and perfectly matched clamping length
- No torque control required given by reduced thread
- Secured against unwinding given by reduced thread
- Connecting components are pulled together during setting process given by reduced thread
- Fastener can be over-tightened

Documentation

Technical Data

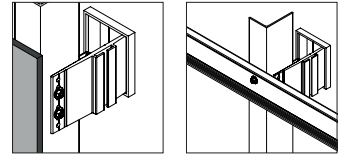

Fastener in A4 onto aluminium

Product code	PU	L	CL	
SDA5/3,5-7-D11/T20-4,8×22-A4	250	22	3.5-7.0	1711845

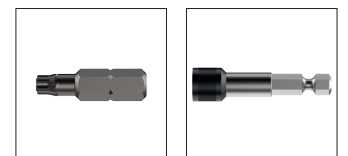

Accessories/Ancillaries

Product code	PU	L	Drive	Head drive	
T20-25-HEX $\frac{1}{4}$ "	10	25	$\frac{1}{4}$ "	T20	769471
Bit holder ZA $\frac{1}{4}$ "	1	58		$\frac{1}{4}$ "	1162306

SW3-4.8

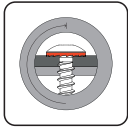
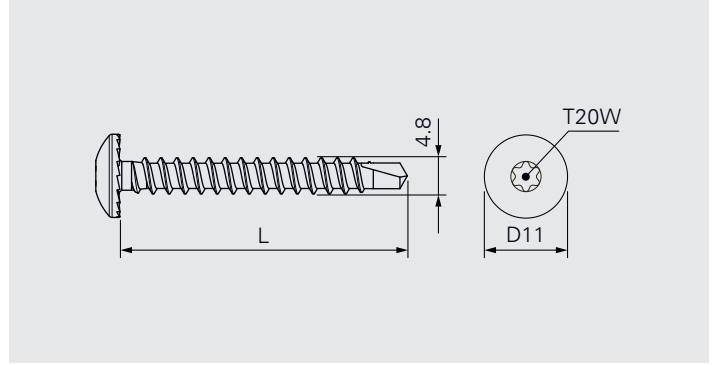

Application

Fastening of aluminium profile to timber batten

Component 1 (t₁)

Aluminium

≤3.0

Component 2 (t₂)

Timber

≥12

Fastener material

Austenitic stainless steel A2

Approvals

CE₁₈
EN 14592:2008

Features and Benefits

- Self drilling fastener suitable for installation of aluminium profiles onto timber
- No pre-drilling of the aluminium rail needed
- Secured against over-torquing given by rips under the head

Documentation

Declaration of performance (DOP) | Technical Data

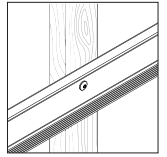

Fastener in A2 onto timber

Product code	PU	L	
SW3-S-D11/R-4,8x38	250	38	1563413

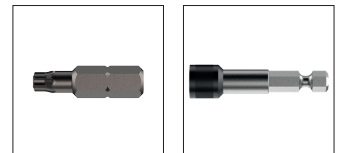

Accessories/Ancillaries

Product code	PU	L	Drive	Head drive	
T20W-25-HEX $\frac{1}{4}$ "	1	25	$\frac{1}{4}$ "	T20W	895280
Bit holder ZA $\frac{1}{4}$ "		58		$\frac{1}{4}$ "	

SDA2-4.8

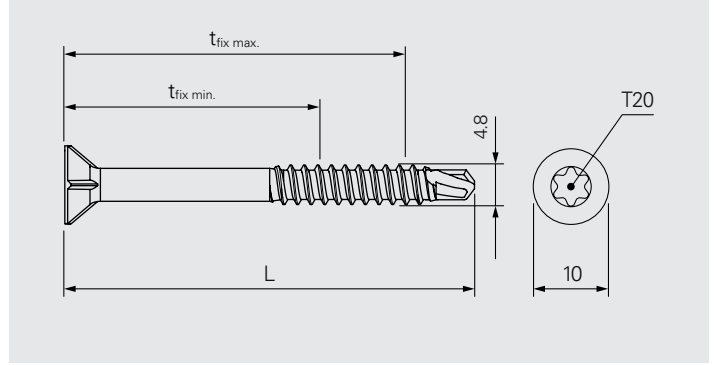
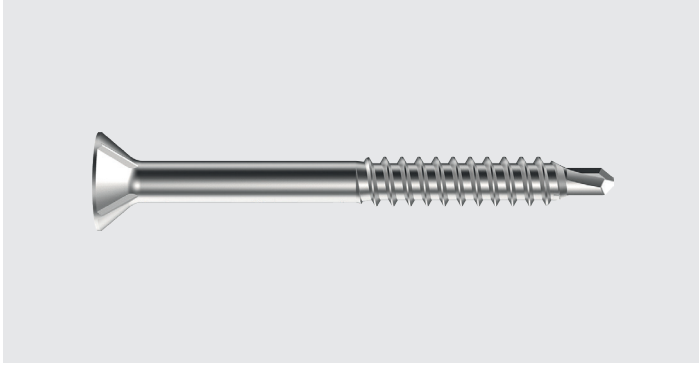

Application

Fastening of timber batten to aluminium profile

Component 1 (t₁)

Timber

20–40

Component 2 (t₂)

Aluminium

1.8–2.2

Fastener material

Austenitic stainless steel A2

Approvals

–

Features and Benefits

- Self drilling fastener suitable for installation of timber battens onto aluminium structure
- Variable application range given by large clamping range
- Low insertion torque during installation given by adjusted clamping range
- Flush-mounted installation without damaging the timber surface given by the milling grooves

Documentation

Technical Data

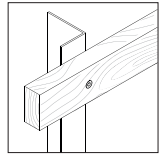

Fastener in A2 onto aluminium

Product code	PU	L	t _{fix, timb}	
SDA2/20-30-S10/T20-4,8x38-A2	250	38	20-30	1711843
SDA2/30-40-S10/T20-4,8x48-A2		48	30-40	1711844

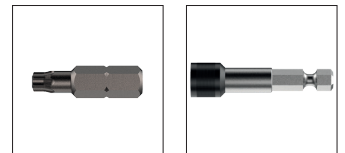

Accessories/Ancillaries

Product code	PU	L	Drive	Head drive	
T20-25-HEX $\frac{1}{4}$ "	1	25	$\frac{1}{4}$ "	T20	769471
Bit holder ZA $\frac{1}{4}$ "		58		$\frac{1}{4}$ "	1162306



University Peabody Building



Third level fixing

AP-5.0

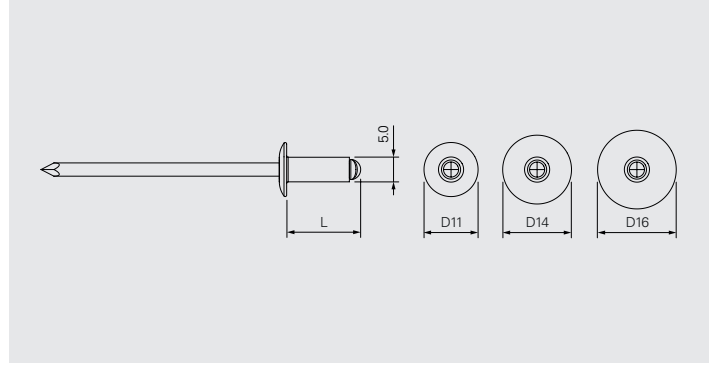
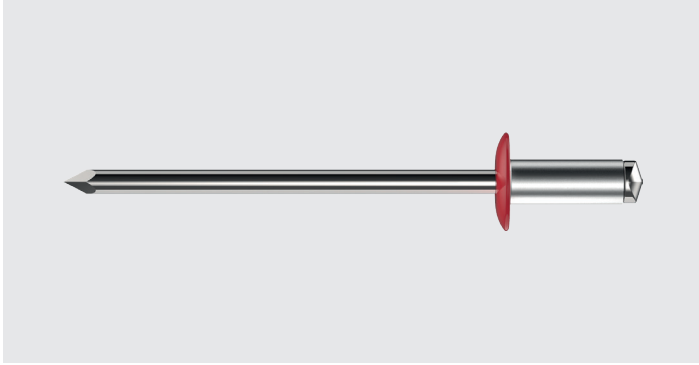

Application

Fastening of cladding panel to aluminium profile

Component 1 (t₁)

Cladding panel

Component 2 (t_{II})

Aluminium	≥1.0
Pre-drill Ø	5.1

Fastener material

Body: Aluminium AlMg5

Mandrel: Austenitic stainless steel A2

Approvals

ETA-21/0951

Features and Benefits

- Blind rivet suitable for installation of pre-drilled cladding panels onto pre-drilled aluminium structure
- High clamping range with clamping force independent of the clamping thickness
- Non-detachable and vibration-resistant connection

Documentation

Approval document (ETA)

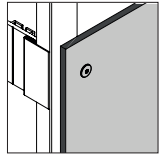

Blind rivet in aluminium onto aluminium

Product code	PU	L	CL	Head	Blank	Coloured
AP11-50120-S	250	12	2.0–8.0	D11	995901	1363826
AP11-50180-S		18	7.0–13.5		883751	1363851
AP14-50120-S		12	2.0–8.0	D14	941481	1363853
AP14-50160-S		16	6.0–12.0		1127413	1363854
AP14-50180-S		18	7.0–13.5		851318	1363855
AP14-50210-S		21	10.0–16.0		1586734	1363856
AP14-50230-S		23	12.0–18.0		–	1363857
AP16-50120-S		12	2.0–8.0		D16	1656044
AP16-50160-S		16	6.0–12.0	914963		1363858
AP16-50180-S		18	7.0–13.5	870920		1363859
AP16-50210-S		21	10.0–16.0	994642		1363861

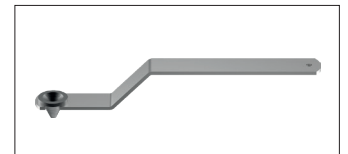
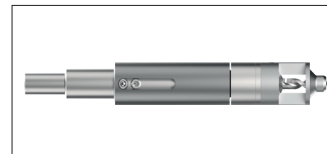
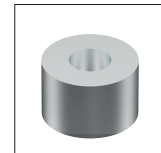

Accessories/Ancillaries

Product code	PU	Pre-drill Ø panel	
AccuBird®Pro	1	–	1679661
FP-A Sleeves	–		–
NOSEPIECE-MOVING-POINT AP/ASO	1		974620
DG-146×20-7,0		7.0–7.9	1320657
DG-146×20-8,0		8.0–8.9	1320658
DG-146×20-9,0		9.0–9.9	1320659
DG-146×20-10,0		10.0–10.9	1321704
ZL-5,1/7-18		7.0–18.0	701532

ASO-5.0

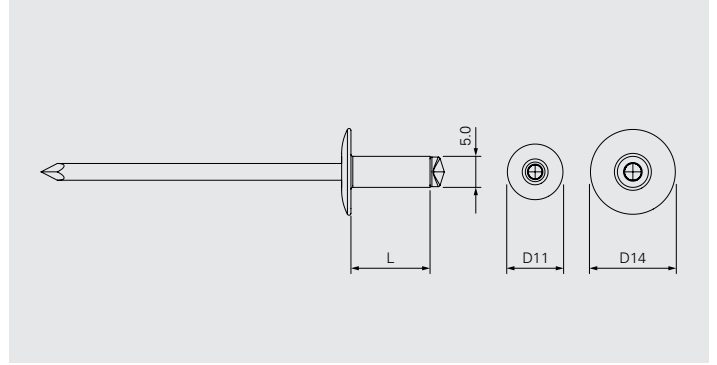
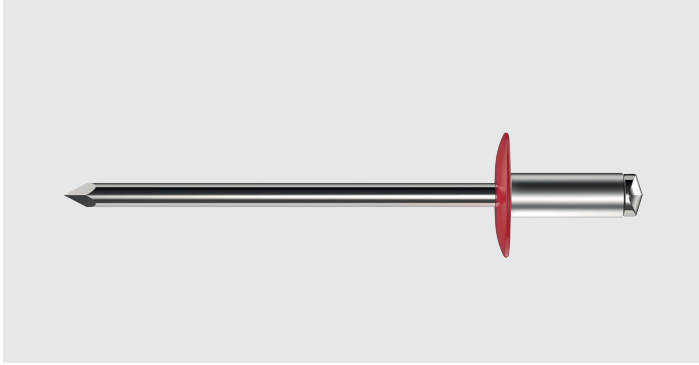

Application

Fastening of cladding panel to aluminium profile

Component 1 (t₁)

Cladding panel

Component 2 (t_{II})

Aluminium	≥1.0
Pre-drill Ø	5.1

Fastener material

Body: Aluminium AlMg3

Mandrel: Austenitic stainless steel A2

Approvals

ETA-21/0951

Features and Benefits

- Blind rivet suitable for installation of pre-drilled cladding panels onto pre-drilled aluminium structure
- High clamping range with clamping force independent of the clamping thickness
- Non-detachable and vibration-resistant connection

Documentation

Approval document (ETA)

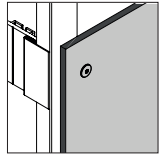

Blind rivet in aluminium onto aluminium

Product code	PU	L	CL	Head	Blank	Coloured
ASO-D11-50080	250	8	2.0–4.5	D11	-	1363862
ASO-D11-50100		10	2.0–6.0		-	1363863
ASO-D11-50120		12	2.0–8.0		262251	1363864
ASO-D11-50140		14	4.0–10.0		1208418	1363865
ASO-D11-50160		16	6.0–12.0		1208450	1363868
ASO-D14-50080		8	2.0–4.5		D14	-
ASO-D14-50100	10	2.0–6.0	-	1363870		
ASO-D14-50120	12	2.0–8.0	-	1363881		
ASO-D14-50140	14	4.0–10.0	-	1363882		
ASO-D14-50160	16	6.0–12.0	1270352	1363883		

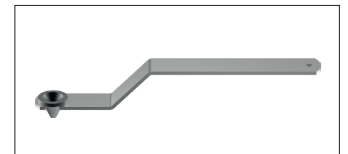
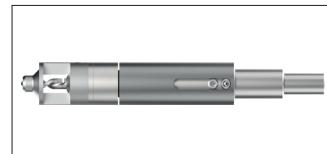
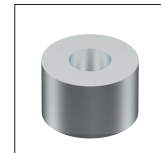

Accessories/Ancillaries

Product code	PU	Pre-drill Ø panel	
AccuBird®Pro	1	-	1679661
FP-A Sleeves	-		-
NOSEPIECE-MOVING-POINT AP/ASO	1		974620
DG-146×20-7,0		7.0–7.9	1320657
DG-146×20-8,0		8.0–8.9	1320658
DG-146×20-9,0		9.0–9.9	1320659
DG-146×20-10,0		10.0–10.9	1321704
ZL-5,1/7-18		7.0–18.0	701532

SSO-5.0

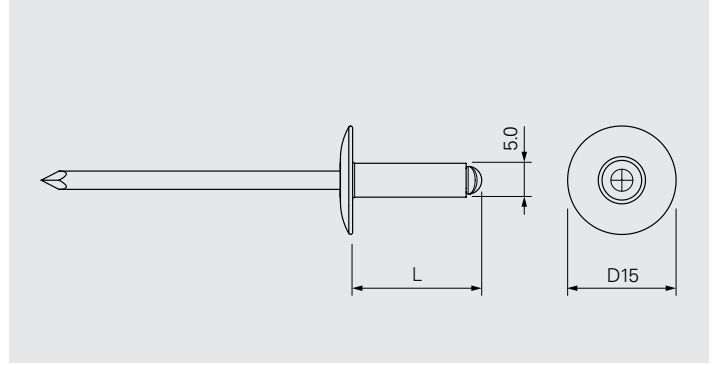
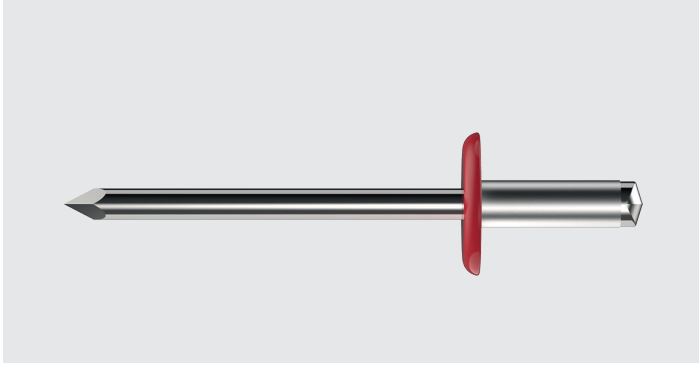

Application

Fastening of cladding panel to aluminium or steel rail

Component 1 (t₁)

Cladding panel

Component 2 (t_{II})

Aluminium

≥1.0

Pre-drill Ø

5.1

Cladding panel

Steel

≥1.0

Pre-drill Ø

5.1

Fastener material

Body: Austenitic stainless steel A4

Mandrel: Austenitic stainless steel A4

Approvals

ETA-21/0951

Features and Benefits

- Blind rivet suitable for installation of pre-drilled cladding panels onto pre-drilled aluminium or steel structure
- High clamping range with clamping force independent of the clamping thickness
- Non-detachable and vibration-resistant connection

Documentation

Approval document (ETA)

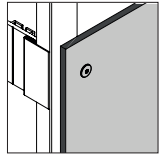

Blind rivet in A4 onto aluminium and steel

Product code	PU	L	CL	Blank	Coloured
SSO-D15-50140	250	14	4.0–9.5	1262436	1363885
SSO-D15-50180		18	8.0–13.5	1262437	1363886
SSO-D15-50220		22	12.0–18.0	1262439	1363887
SSO-D15-50270		27	17.0–22.0	–	1685313

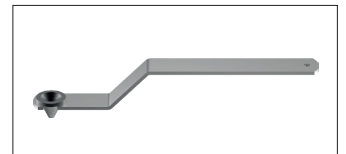
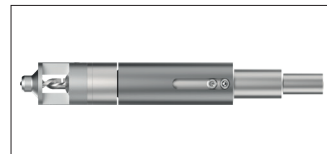
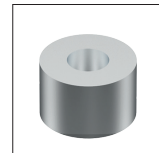

Accessories/Ancillaries

Product code	PU	Pre-drill Ø panel	
AccuBird®Pro	1	–	1679661
FP-S Sleeves	–		–
NOSEPIECE-MOVING-POINT-SSO-D15-50xL	1		1291200
DG-146x20-7,0		7.0–7.9	1320657
DG-146x20-8,0		8.0–8.9	1320658
DG-146x20-9,0		9.0–9.9	1320659
DG-146x20-10,0		10.0–10.9	1321704
ZL-5,1/7-18		7.0–18.0	701532

TDA-S-5.8

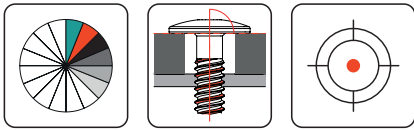
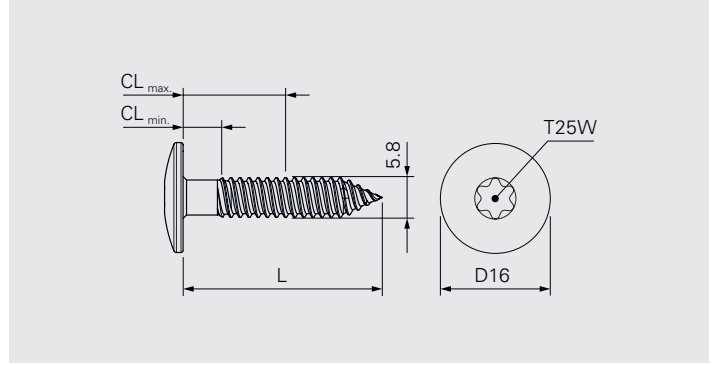
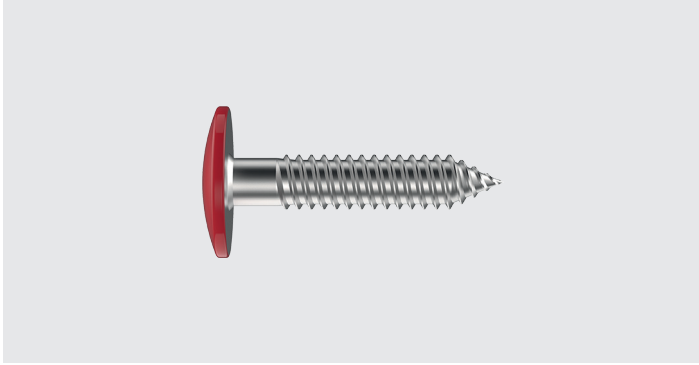

Application

Fastening of cladding panel to aluminium or steel profile

Component 1 (t₁)

Cladding panel

Component 2 (t_{II})

Aluminium

1.8–3.0

Pre-drill Ø

4.5

Cladding panel

Steel

1.2–3.0

Pre-drill Ø

4.5

Fastener material

Austenitic stainless steel A2

Approvals



ETA-10/0198

Features and Benefits

- Self tapping fastener suitable for installation of cladding panels onto pre-drilled aluminium or steel structure
- Secured against unwinding given by reduced thread
- Alignment of the fastener to the panel is always set straight given by double-threaded thread

Documentation

Approval document (ETA) | Declaration of performance (DoP)

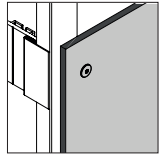

Fastener in A2 onto aluminium and steel

Product code	PU	L	CL	Blank	Coloured
TDA-S-D16-5,8×29	250	29	6-20	1572881	1691521

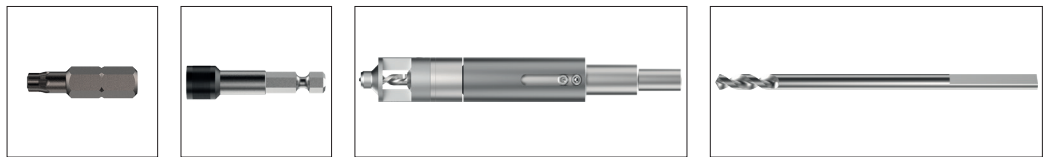

Accessories/Ancillaries

Product code	PU	L	Drive	Head drive	Pre-drill Ø panel	
T25W-25-HEX¼"	1	25	¼"	T25W	–	7662
Bit holder ZA¼"		58		¼"		1162306
DG-146×20-7,0	146	146	–	–	7-7.9	1320657
DG-146×20-8,0		146			8-8.9	1320658
DG-146×20-9,0		146			9-9.9	1320659
DG-146×20-10,0		146			10-10.9	1321704
HSS-DG-4,5×110		110			–	1573824



Center Point

System



SX4-5.8

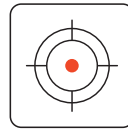
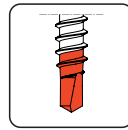
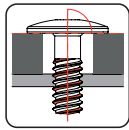
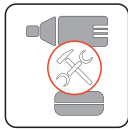
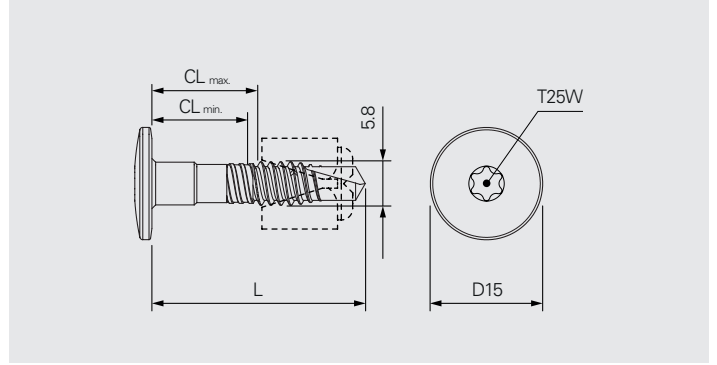

Application

Self drilling fastener for fixing a façade panel to steel or aluminium rails

Component 1 (t₁)

Cladding panel

Component 2 (t_{II})

Aluminium	1.8–3.0
Steel	1.2–2.0

Fastener material

Austenitic stainless steel A4, case hardened drill point
Centering sleeve: PMMA

Approvals



Features and Benefits

- Self drilling fastener suitable for installation of pre-drilled cladding panels onto steel or aluminum structure
- Installation of fastener precisely centric to the pre-drilled panel given by centering sleeve
- Dilatation can be fully utilised as no residual material from the centring sleeve remains in the drill hole
- Both impact gun and regular drill gun machine can be used for installation
- No torque control required given by reduced thread
- Secured against unwinding given by reduced thread
- Alignment of the fastener to the panel is always set straight given by double-threaded thread
- Fastener head is slightly conical, thus no abrasion on the panel surface after dilatation
- Fastener can be over-tightened

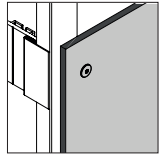

Fastener in A4 with centering sleeve onto aluminium or steel

Product code	PU	L	Pre-drill Ø panel	CL _{Aluminium}	CL _{Steel}	t _{l, panel}	
SX4-D15-CS10/6-5.8×25-A4	250	25	10.0	7.8–9.0	7.2–8.0	6.0	1696657
SX4-D15-CS10/8-5.8×29-A4		29		9.8–11.0	9.2–10.0	8.0	1693558
SX4-D15-CS10/10-5.8×33-A4		33		11.8–13.0	11.2–12.0	10.0	1693559
SX4-D15-CS10/13-5.8×38-A4		38		13.8–16.0	13.2–15.0	12.0–13.0	1693563

Fastener in A4 without centering sleeve onto aluminium or steel

Product code	PU	L	CL _{Aluminium}	CL _{Steel}	t _{l, panel}	
SX4-D15-6-5.8×25-A4	250	25	7.8–9.0	7.2–8.0	6.0	1696656
SX4-D15-8-5.8×29-A4		29	9.8–11.0	9.2–10.0	8.0	1693363
SX4-D15-10-5.8×33-A4		33	11.8–13.0	11.2–12.0	10.0	1693365
SX4-D15-13-5.8×38-A4		38	13.8–16.0	13.2–15.0	12.0–13.0	1678524

Centering sleeve in PMMA

Product code	PU	L	Pre-drill Ø panel	
CS10/4	250	5.5	10.0	1693410

Installation instruction

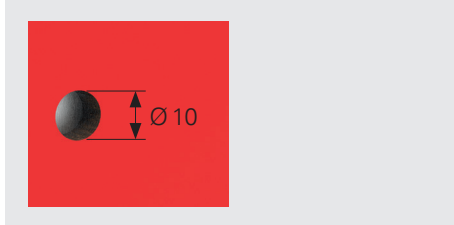

- Panel needs to be pre-drilled to \varnothing 10 mm



- Wearing safety glasses is recommended during the entire setting process



- The bit supplied in the box must be used

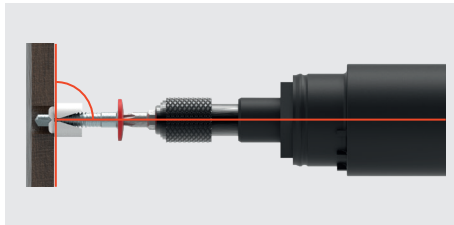

- Ensure a right angle during the entire setting process
- Make sure that the bit is mounted without play in the screwdriver



- Apply pressure at low rotation-speed until the centering sleeve breaks



- Once the centering sleeve is broken, apply more pressure and increase the rotation-speed



Accessories/Ancillaries

Product code	PU	D	L	Drive	Head drive	
FP-S-10.0x6-6.0	100	10	6	-	-	1696117
GP-S-10.0x6-6.0						1696118
VHM-10.0x80	1		80			1677551
GP-H-10.0-CPS			-			1697297
T25W-25-HEX $\frac{1}{4}$ "			-			25
Bit holder ZA $\frac{1}{4}$ "			58		$\frac{1}{4}$ "	1162306



SDA4-5.8

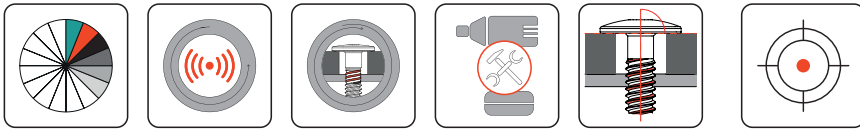
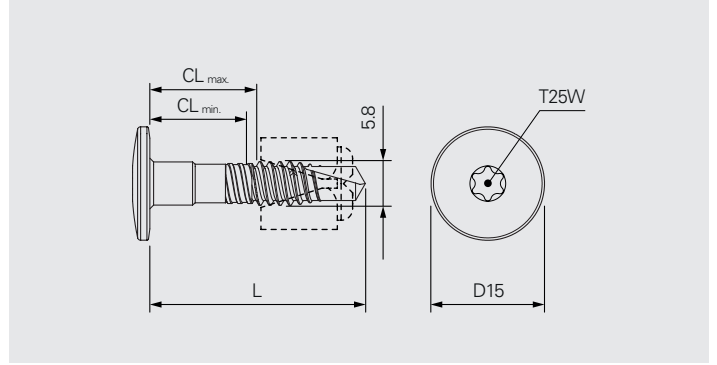

Application

Self drilling fastener for fixing a façade panel to aluminium rails

Component 1 (t₁)

Cladding panel

Component 2 (t_{II})

Aluminium

1.8–3.0

Fastener material

Austenitic stainless steel A4
Centering sleeve: PMMA

Approvals



Features and Benefits

- Self drilling fastener suitable for installation of pre-drilled cladding panels onto steel or aluminum structure
- Installation of fastener precisely centric to the pre-drilled panel given by centering sleeve
- Dilatation can be fully utilised as no residual material from the centring sleeve remains in the drill hole
- Both impact gun and regular drill gun machine can be used for installation
- No torque control required given by reduced thread
- Secured against unwinding given by reduced thread
- Alignment of the fastener to the panel is always set straight given by double-threaded thread
- Fastener head is slightly conical, thus no abrasion on the panel surface after dilatation
- Fastener can be over-tightened

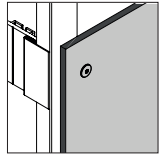

Fastener in A4 with centering sleeve onto aluminium

Product code	PU	L	Pre-drill Ø panel	CL	t _{l, panel}	
SDA4-D15-CS10/6-5,8×25-A4	250	25	10.0	7.8–9.0	6.0	1696036
SDA4-D15-CS10/8-5,8×29-A4		29		9.8–11.0	8.0	1693404
SDA4-D15-CS10/10-5,8×33-A4		33		11.8–13.0	10.0	1693540
SDA4-D15-CS10/13-5,8×38-A4		38		13.8–16.0	12.0–13.0	1693557

Fastener in A4 without centering sleeve onto aluminium

Product code	PU	L	CL	t _{l, panel}	
SDA4-D15-6-5,8×25-A4	250	25	7.8–9.0	6.0	1696067
SDA4-D15-8-5,8×29-A4		29	9.8–11.0	8.0	1661703
SDA4-D15-10-5,8×33-A4		33	11.8–13.0	10.0	1661834
SDA4-D15-13-5,8×38-A4		38	13.8–16.0	12.0–13.0	1661836

Centering sleeve in PMMA

Product code	PU	L	Pre-drill Ø panel	
CS10/4	250	5.5	10.0	1693410

Installation instruction

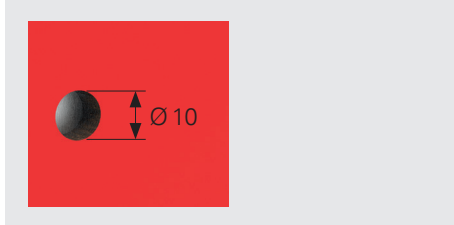

- Panel needs to be pre-drilled to \varnothing 10 mm



- Wearing safety glasses is recommended during the entire setting process



- The bit supplied in the box must be used

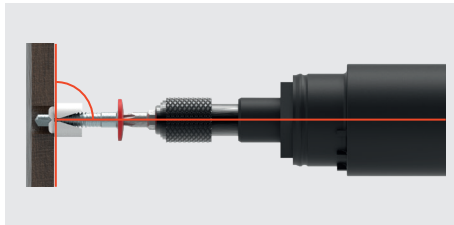

- Ensure a right angle during the entire setting process
- Make sure that the bit is mounted without play in the screwdriver



- Apply pressure at low rotation-speed until the centering sleeve breaks



- Once the centering sleeve is broken, apply more pressure and increase the rotation-speed



Accessories/Ancillaries

Product code	PU	D	L	Drive	Head drive	
FP-S-10.0×6-6.0	100	10	6	-	-	1696117
GP-S-10.0×6-6.0						1696118
VHM-10.0×80	1		80			1677551
GP-H-10.0-CPS			-			1697297
T25W-25-HEX $\frac{1}{4}$ "			-			25
Bit holder ZA $\frac{1}{4}$ "			58		$\frac{1}{4}$ "	1162306



SX3-5.5

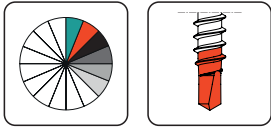
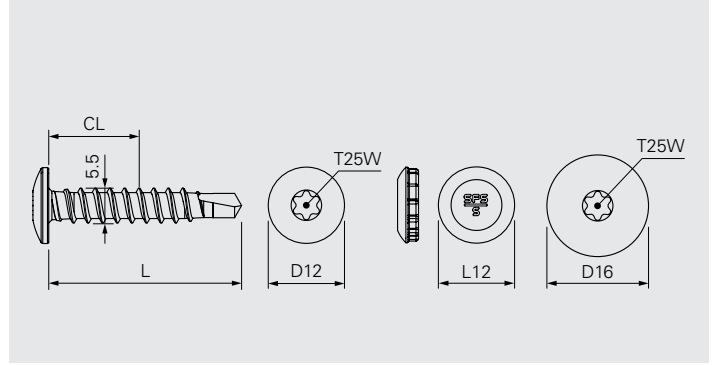

Application

Fastening of cladding panel to aluminium or steel profile

Component 1 (t₁)

Cladding panel

Component 2 (t_{II})

Aluminium	2.2–3.0
Steel	1.5–2.5

Fastener material

Austenitic stainless steel A2/A4, case hardened drill point

Approvals



Features and Benefits

- Self drilling fastener suitable for fastening cladding panel onto aluminium or steel structure
- No pre-drilling of the rail needed
- Secured against unwinding given by coned shape

Documentation

Approval document (ETA) | Declaration of performance (DoP)

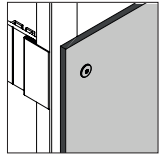

Fastener in A2 onto aluminium and steel

Product code	PU	L	CL	Head	Washer	Blank	Coloured
SX3/15-D12-5,5×30-A2	250	30	0-15	D12	-	1271253	1627480
SX3/15-D16-5,5×30		30		D16	-	1270106	1518302
SX3/15-L12-S16/1-5,5×32		32		L12	S16/A2	1235593	1403191

Fastener in A4 onto aluminium and steel

Product code	PU	L	CL	Head	Washer	Blank	Coloured
SX3/15-D12-5,5×30-A4	250	30	0-15	D12	-	1548549	1606159
SX3/15-L12-S16/A4-5,5×32-A4		32		L12	S16/A4	-	1614691

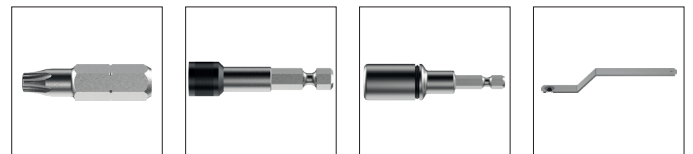

Accessories/Ancillaries

Product code	PU	L	Drive	Head drive	Pre-drill Ø Panel	
T25W-25-HEX¼"	1	25	¼"	T25W	-	7662
Bit holder ZA¼"		58		¼"		1162306
E420-¼"-74		74		L12		973316
ZL-SX/SD-5,5/8,0		-	-	-	8.0	774499

SX3-4.8

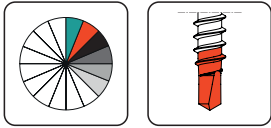
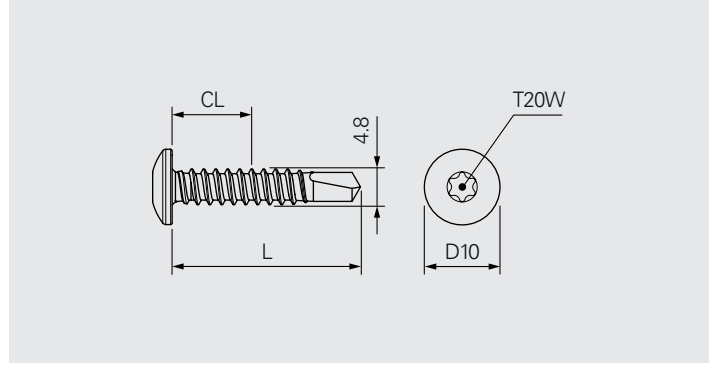
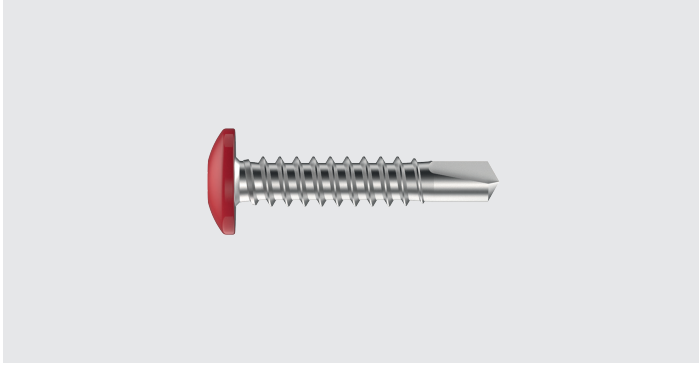

Application

Fastening of cladding panel to aluminium or steel profile

Component 1 (t ₁)		Component 2 (t _{II})		$\Sigma_{\max} t_1 + t_{II}$
Cladding panel	–	Aluminium	2.2–3.0	–
		Steel	1.5–2.5	
Steel	1.2–1.8	Steel	1.2–1.8	3.0
Steel	1.2–3.0	Steel	1.2–3.0	–
Pre-drill Ø	5.0			

Fastener material

Austenitic stainless steel A2, case hardened drill point

Approvals



Features and Benefits

- Self drilling fastener suitable for fastening cladding panel onto aluminium or steel structure
- No pre-drilling of the rail needed
- Secured against unwinding given by coned shape

Documentation

Approval document (ETA) | Declaration of performance (DoP)

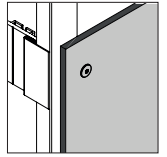

Fastener in A2 onto aluminium and steel

Product code	PU	L	CL	Blank	Coloured
SX3/11-D10-4,8x25	250	25	0-11	-	1416351
SX3/11-D10-4,8x25	500			1193547	-



Accessories/Ancillaries

Product code	PU	L	Drive	Head drive	Pre-drill Ø Panel	
T20W-25-HEX 1/4"	1	25	1/4"	T20W	-	895280
Bit holder ZA 1/4"		58		1/4"		1162306
ZL-SLA-4,8/7,0		-	-	-	7.0	1090740

TW-S-4.8

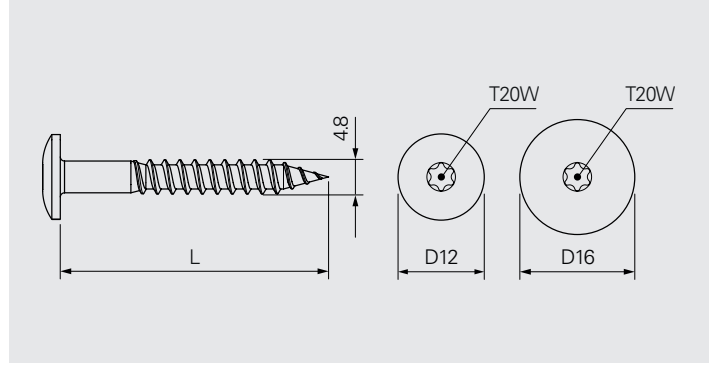
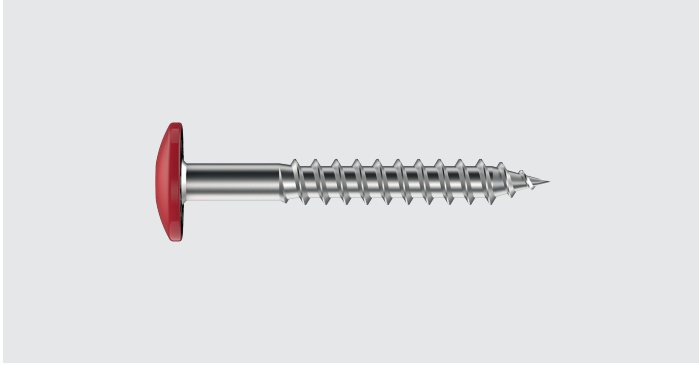

Application

Fastening of cladding panels to timber batten

Component 1 (t_i)

Cladding panel

Component 2 (t_{ii})

Timber

Fastener material

Fastener: Austenitic stainless steel A2

Washer: Austenitic stainless steel A2 with EPDM-seal

Approvals

EN 14592:2008

Features and Benefits

- Self drilling fastener suitable for installation of pre-drilled cladding panels onto timber batten
- Thanks to the threaded tip, the fastener grips immediately and is pulled into the timber
- Large product range allows versatile applications
- Thread geometry prevents splitting of timber
- EPDM tape is easily penetrated

Documentation

Declaration of performance (DoP) | Technical Data

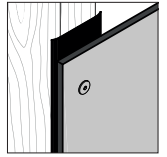

Fastener in A2 onto timber

Product code	PU	L	Head	Blank	Coloured
TW-S-D12-4,8×25	250	25	D12	902988	1363888
TW-S-D12-4,8×30		30		986742	1363889
TW-S-D12-4,8×38		38		1240032	1363890
TW-S-D12-4,8×44		44		–	1363891
TW-S-D12-4,8×60		60		–	1363892
TW-S-D16-4,8×38		38	D16	–	1363897

Fastener in A2 with washer onto timber

Product code	PU	L	Head	Washer	Blank	Coloured
TW-S-D12-S12-4,8×38	250	38	D12	S12	774892	1394550
TW-S-D12-S12-4,8×44		44			730224	1650508
TW-S-D12-S12-4,8×60		60			–	1583024
TW-S-D12-S16-4,8×38		38		S16	1114336	1616457
TW-S-D16-S16-4,8×38		38			D16	–

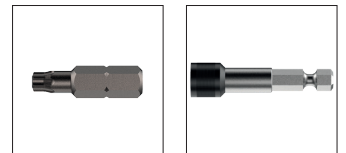

Accessories/Ancillaries

Product code	PU	L	Drive	Head drive	
T20W-25-HEX¼"	1	25	¼"	T20W	895280
Bit holder ZA¼"		58		¼"	1162306

TW-A4-4.8

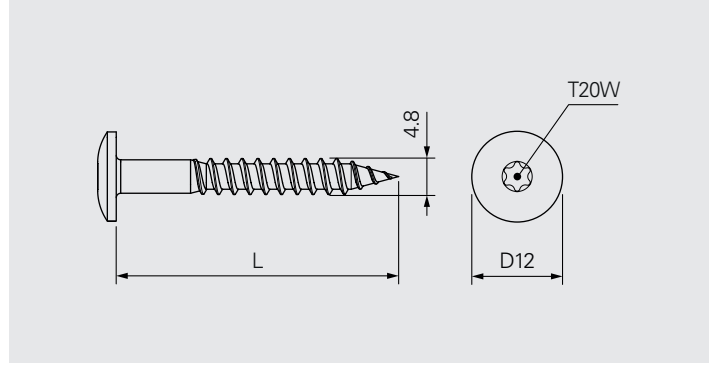
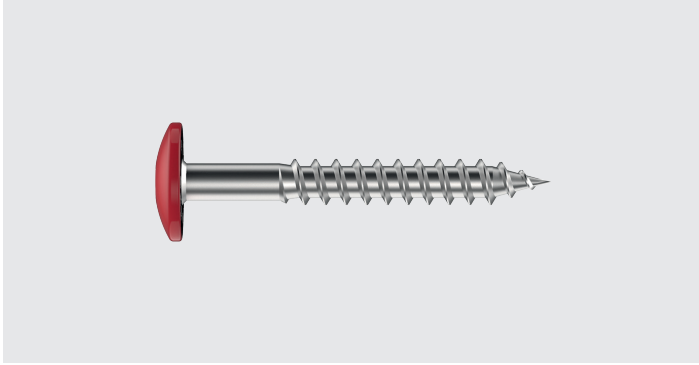

Application

Fastening of cladding panels to timber batten

Component 1 (t_i)

Cladding panel

Component 2 (t_{ii})

Timber

Fastener material

Fastener: Austenitic stainless steel A4

Washer: Austenitic stainless steel A4 with EPDM-seal

Approvals

EN 14592:2008

Features and Benefits

- Self drilling fastener suitable for installation of pre-drilled cladding panels onto timber batten
- Thanks to the threaded tip, the fastener grips immediately and is pulled into the timber
- Thread geometry prevents splitting of timber
- EPDM tape is easily penetrated

Documentation

Declaration of performance (DoP) | Technical Data

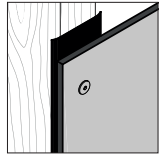

Fastener in A4 onto timber

Product code	PU	L	Blank	Coloured
TW-A4-D12-4,8×38	250	38	914772	1363894

Fastener in A4 with washer onto timber

Product code	PU	L	Washer	Coloured
TW-A4-D12-S12-4,8×38	250	38	S12	1419939
TW-A4-D12-S16-4,8×38	250	38	S16	1685717

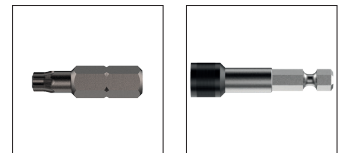

Accessories/Ancillaries

Product code	PU	L	Drive	Head drive	
T20W-25-HEX $\frac{1}{4}$ "	1	25	$\frac{1}{4}$ "	T20W	895280
Bit holder ZA $\frac{1}{4}$ "		58		$\frac{1}{4}$ "	

SCFW-S-5.0

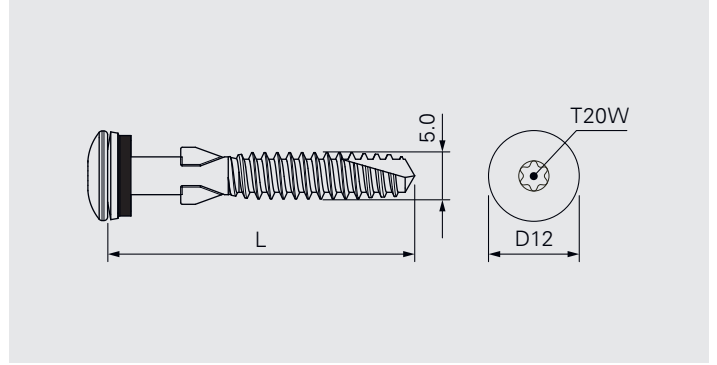
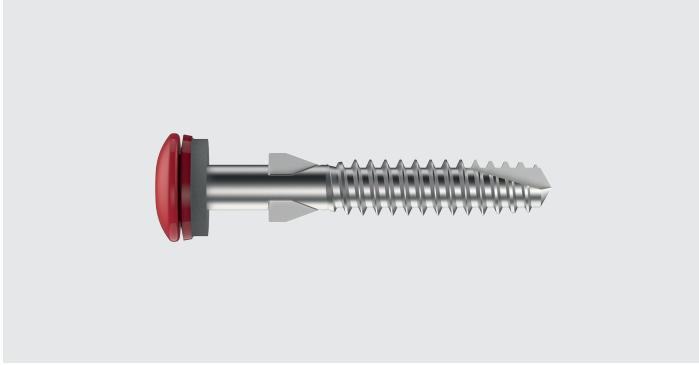

Application

Fastening of a fibre cement board onto timber batten

Component 1 (t₁)

Cladding panel

Component 2 (t_{II})

Timber

Fastener material

Fastener: Austenitic stainless steel A2

Washer: Aluminium with EPDM-seal

Approvals



ETA-22/0793

Features and Benefits

- Self drilling fastener suitable for fastening fibre cement panels onto timber
- No pre-drilling of fibre cement board required thanks to expanding wings
- Fast installation thanks to the threaded drill point

Documentation

Approval document (ETA) | Declaration of performance (DoP)

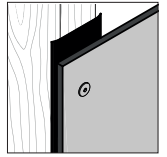

Fastener in A2 onto timber

Product code	PU	L	t _{l, panel}	Blank	Coloured
SCFW-S-D12K-A12-5x42	250	42	≤8.0	861183	1391815

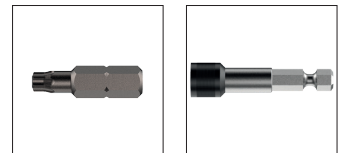

Accessories/Ancillaries

Product code	PU	L	Drive	Head drive	
T20W-25-HEX 1/4"	1	25	1/4"	T20W	895280
Bit holder ZA 1/4"		58		1/4"	1162306

HTP-5.0

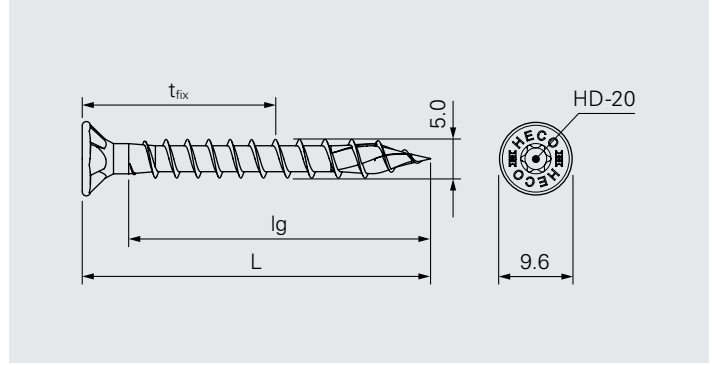

Application

Fastening of timber onto timber

Component 1 (t_I)

Timber

Component 2 (t_{II})

Timber

Fastener material

Fastener: Austenitic stainless steel A2

Approvals



ETA-19/0553

Features and Benefits

- Self drilling fastener suitable for installation of timber battens onto timber
- Patented full thread pulls timber fixtures together without gaps and without pretension
- The fastener is quicker at the front than at the back
- Special drive for single-handed operation
- Antifriction-coated for minimal driving torques

Documentation

Approval document (ETA) | Declaration of performance (DoP)

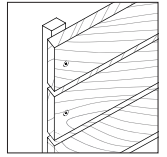

Fastener in A2 onto timber

Product code	PU	L	lg	t _{fix, max.}	
HTP-S-CS-VFT-5,0x45/39	200	45	39	25	1205736
HTP-S-CS-VFT-5,0x50/44		50	44	30	1205737
HTP-S-CS-VFT-5,0x60/54		60	54	40	1205738
HTP-S-CS-VFT-5,0x70/64		70	64	50	1205738

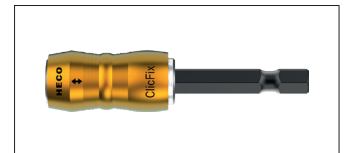

Accessories/Ancillaries

Product code	PU	L	Drive	Head drive	
HD20-25mm	10	25	1/4"	HD-20	1205164
HECO-ClicFix	1	60		1/4"	

Concealed fixing solution





TUF-S

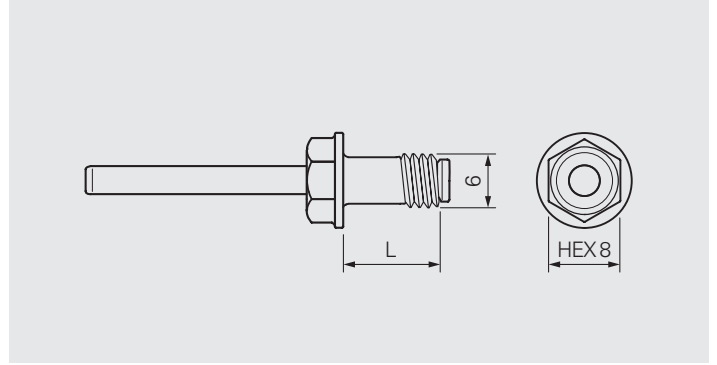
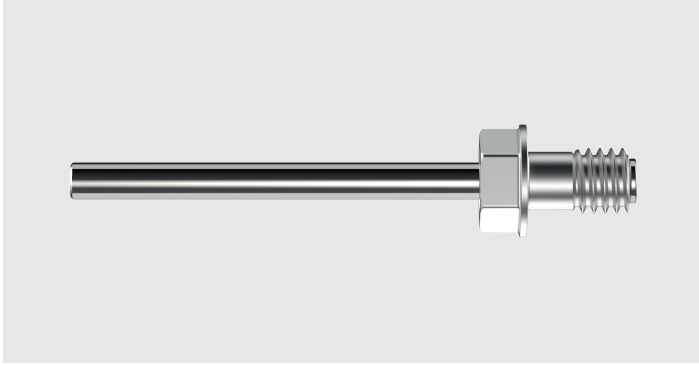

Application

Concealed fastener for fixing a metal hanger to cladding panel

Component 1 (t_I)

Metal hanger
Pre-drill Ø 6.5–7.0

Component 2 (t_{II})

Cladding panel	–
Pre-drill Ø	5.9–6.0

Fastener material

Body: Austenitic stainless steel A4
Mandrel: Carbon steel

Approvals



Features and Benefits

- Concealed fastener suitable for installation of a metal hanger onto cladding panel
- Secured against unwinding
- Time saving installation compared to conventional blind attachments
- Simple standard blind hole sufficient - no complex undercut hole required
- Quick and easy installation with battery rivet gun
- Blind holes can even be drilled on site
- Removable possible via hex head

Documentation

Approval document (ETA) | Declaration of performance (DoP) | Technical Data

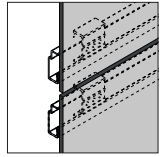

Fastener in A4 onto cladding panel

Product code	PU	L	
TUF-S-6×7-A4	250	7	1692229
TUF-S-6×7.5-A4		7.5	1692230
TUF-S-6×8-A4		8	1692241
TUF-S-6×8.5-A4		8.5	1692243
TUF-S-6×9-A4		9	1692245
TUF-S-6×10-A4		10	1692253
TUF-S-6×11-A4		11	1692254
TUF-S-6×12-A4		12	1692255
TUF-S-6×13-A4		13	1692256

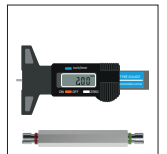
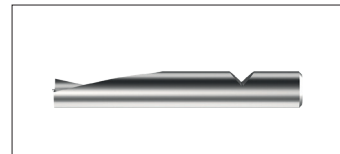

Accessories/Ancillaries

Product code	PU	L	Drill depth	Drive	D	
Accu-Bird®	1	-	-	-	-	1679661
Depth locator universal				HEX8		1478567
VHM-6,0×40	-	40	5	-	6	1615070
VHM-6,0×40,5		40.5	5.5			1586737
VHM-6,0×41		41	6			1615072
VHM-6,0×41,5		41.5	6.5			1615073
VHM-6,0×42		42	7			1615074
VHM-6,0×42,5		42.5	7.5			1615075
VHM-6,0×43		43	8			1615077
VHM-6,0×43,5		43.5	8.5			1615078
VHM-6,0×45		45	10			1479984
MEASURING-SET-DRILLS-5.9-6.0		-	-			-

TU-S

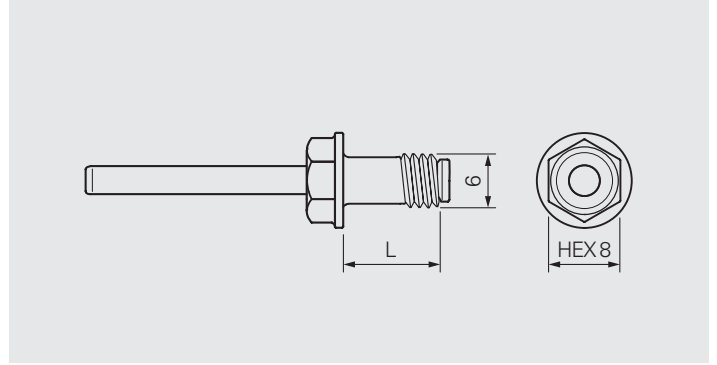
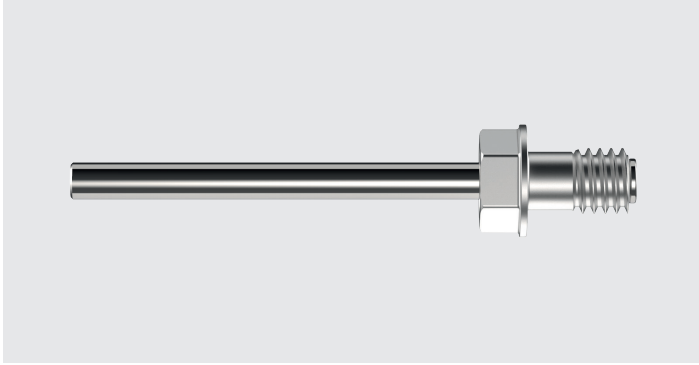

Application

Concealed fastener for fixing a metal hanger to cladding panel

Component 1 (t₁)

Metal hanger
Pre-drill Ø 6.5–7.0

Component 2 (t_{II})

Cladding panel	–
Pre-drill Ø	5.9–6.0

Fastener material

Body: Austenitic stainless steel A4
Mandrel: Carbon steel

Approvals



ETA-18/0883

(Rockpanel Premium A2)

Features and Benefits

- Concealed fastener suitable for installation of a metal hanger onto cladding panel
- Secured against unwinding
- Time saving installation compared to conventional blind attachments
- Simple standard blind hole sufficient - no complex undercut hole required
- Quick and easy installation with battery rivet gun
- Blind holes can even be drilled on site
- Removable possible via hex head

Documentation

Approval document (ETA) | Declaration of performance (DoP)

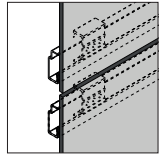

Fastener in A4 onto cladding panel

Product code	PU	L	
TU-S-6×9-A4	250	9	1692257
TU-S-6×11-A4		11	1692258
TU-S-6×13-A4		13	1692260

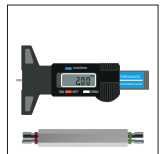
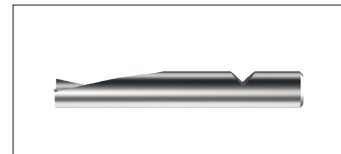

Accessories/Ancillaries

Product code	PU	L	Drill depth	Drive	D	
Accu-Bird®	1	-	-	-	-	1679661
Depth locator universal				HEX8		1478567
VHM-6,0×40	-	40	5	-	6	1615070
VHM-6,0×40,5		40.5	5.5			1586737
VHM-6,0×41		41	6			1615072
VHM-6,0×41,5		41.5	6.5			1615073
VHM-6,0×42		42	7			1615074
VHM-6,0×42,5		42.5	7.5			1615075
VHM-6,0×43		43	8			1615077
VHM-6,0×43,5		43.5	8.5			1615078
VHM-6,0×45		45	10			1479984
MEASURING-SET-DRILLS-5.9-6.0		-	-			-

TUC-S

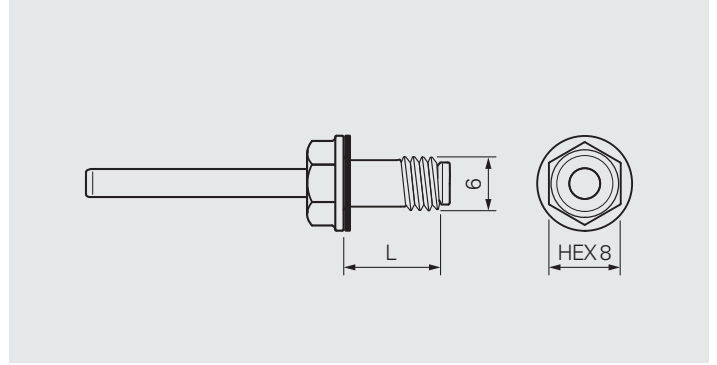
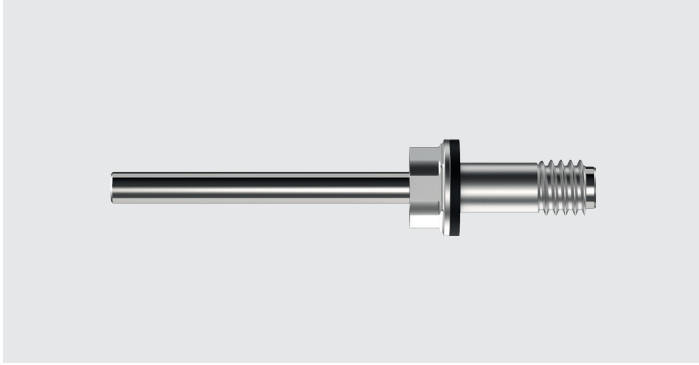

Application

Concealed fastener for fixing a metal hanger to cladding panel

Component 1 (t_i)

Metal hanger
Pre-drill Ø 6.5–7.0

Component 2 (t_{ii})

Cladding panel
Pre-drill Ø 5.9–6.1

Fastener material

Body: Austenitic stainless steel A4
Mandrel: Carbon steel
Washer: EPDM

Approvals

–

Features and Benefits

- Concealed fastener suitable for installation of a metal hanger onto cladding panel
- Secured against unwinding
- Time saving installation compared to conventional blind attachments
- Simple standard blind hole sufficient - no complex undercut hole required
- Quick and easy installation with battery rivet gun
- Blind holes can even be drilled on site
- Removable possible via hex head

Documentation

Technical Data

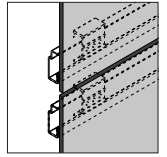

Fastener in A4 onto cladding panel

Product code	PU	L	
TUC-S-W10-6×14-A4	250	14	1745715

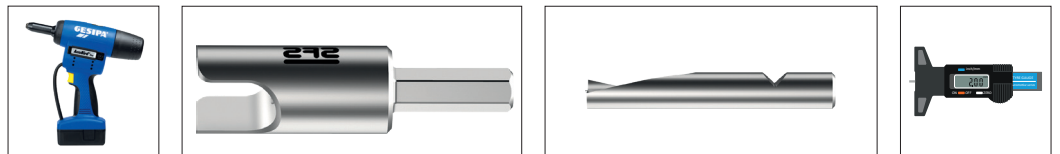

Accessories/Ancillaries

Product code	PU	Drill depth	Drive	
AccuBird®Pro	1	–	–	1679661
Depth locator universal		–	HEX8	1478567
VHM-6,0×45		10.0	–	1479984
MEASURING-SET-DRILLS-5,9–6,1		–	–	1715384

TD-A4

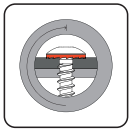
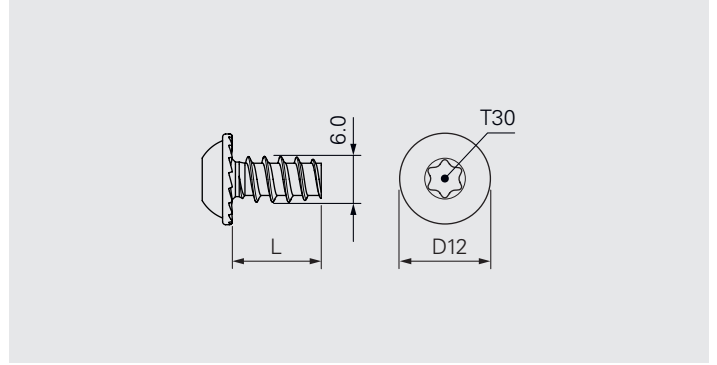
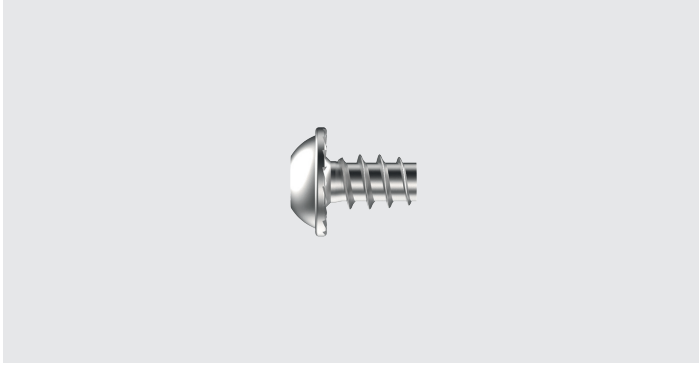

Application

Concealed fastener for fixing a metal hanger to cladding panel

Component 1 (t_i)

Metal hanger
Pre-drill Ø 6.5–7.0

Component 2 (t_{ii})

Cladding panel	≥8.0
Pre-drill Ø	4.9–5.0

Fastener material

Austenitic stainless steel A4

Approvals

–

Features and Benefits

- Concealed fastener suitable for installation of a metal hanger onto cladding panel
- Secured against over-torquing given by rips below the head
- Time saving installation compared to conventional blind attachments
- Simple standard blind hole sufficient - no complex undercut hole required
- Blind holes can even be drilled on site

Documentation

Technical Data

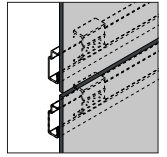

Fastener in A4 onto cladding panel

Product code	PU	L	
TD-A4-D12/R-6×8	500	8	1585584
TD-A4-D12/R-6×9,5		9.5	1585585
TD-A4-D12/R-6×11,5		11.5	1585560
TD-A4-D12/R-6×14,5		14.5	1585587



Accessories/Ancillaries

Product code	PU	L	Drill depth	Drive	Head drive	D	
T30-25-HEX¼"	10	25	–	¼"	T30	–	24010
Bit holder ZA¼"		58	–	¼"	¼"	–	1162306
Depth locator universal	1	–	5.0	HEX8	–	–	1478567
HSS-4,9×40,5		40.5	5.5	–	–	4.9	1586911
HSS-4,9×42,5		42.5	7.5	–	–		1586913
HSS-4,9×45,5		45.5	10.5	–	–		1586914





SLA3-4.8

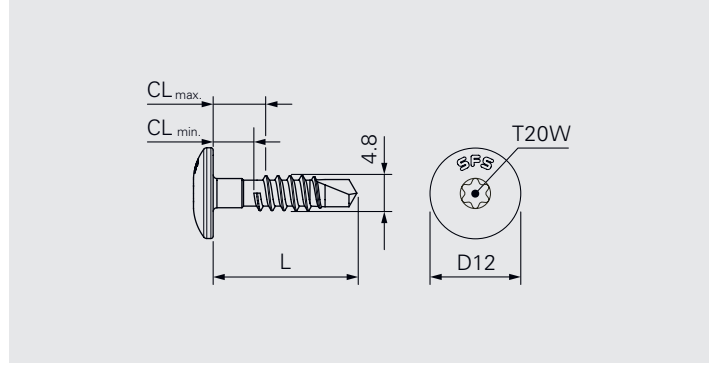
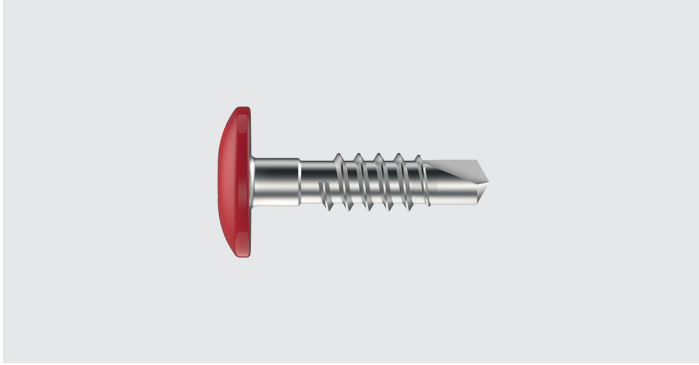

Application

Fastening of aluminium composite panel to aluminium profile

Component 1 (t_i)

Aluminium composite panel

Component 2 (t_{ii})

Aluminium	1.8–2.0
-----------	---------

Fastener material

Austenitic stainless steel A2/A4

Approvals

—

Features and Benefits

- Self drilling fastener suitable for installation of aluminium composite panels onto aluminium structure
- No torque control required given by free-spin zone
- Secured against unwinding given by free-spin zone

Documentation

Technical Data

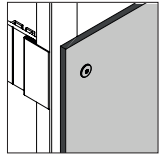

Fastener in A2 onto aluminium

Product code	PU	L	CL	Blank	Coloured
SLA3/6-S-D12-4,8×19	250	19	5-6	1025055	1484045
SLA3/8-S-D12-4,8×21		21	7-8	1343696	1653096

Fastener in A4 onto aluminium

Product code	PU	L	CL	Blank	Coloured
SLA3/6-S4-D12-4,8×19	250	19	5-6	1637109	1419487

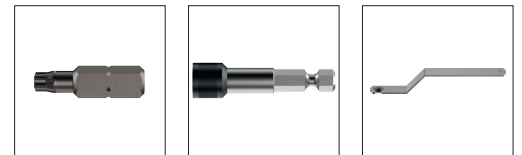

Accessories/Ancillaries

Product code	PU	L	Drive	Head drive	Pre-drill Ø Panel	
T20W-25-HEX ¼"	1	25	¼"	T20W	-	895280
Bit holder ZA ¼"		58		¼"		1162306
ZL-SLA-4,8/7,0		-	-	-	7.0	1090740

SLA5-6.0

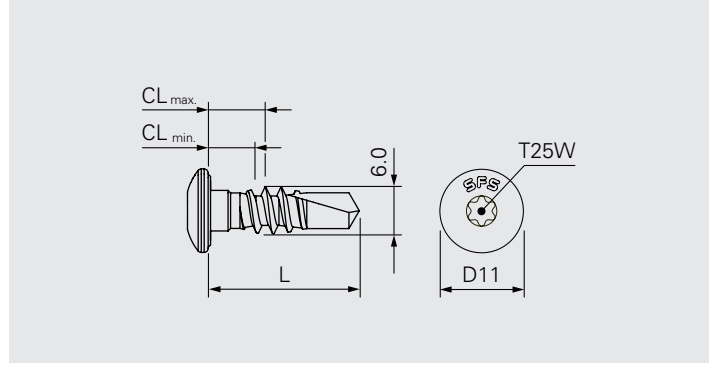
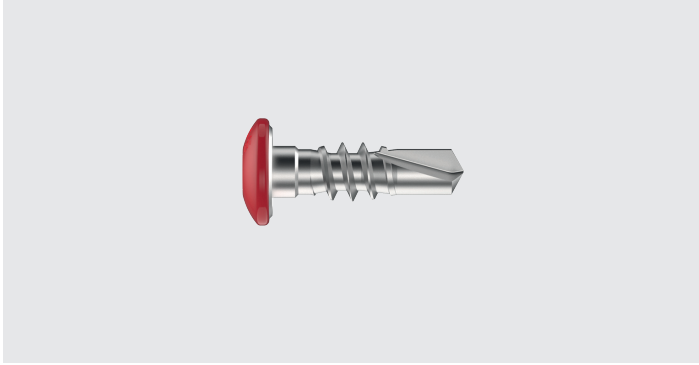

Application

Fastening of aluminium composite panel to aluminium profile

Component 1 (t_i)

Aluminium composite panel

Component 2 (t_{ii})

Aluminium

1.8–2.0

Fastener material

Austenitic stainless steel A2

Approvals

–

Features and Benefits

- Self drilling fastener suitable for installation of aluminium composite panels onto aluminium structure
- No torque control required given by free-spin zone
- Secured against unwinding given by free-spin zone
- Blade under the head to cut the protection film

Documentation

Technical Data

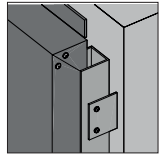

Fastener in A2 onto aluminium

Product code	PU	L	CL	Blank	Coloured
SLA5/5-7-D11-S-6x20	500	20	5-7	1473414	1592312

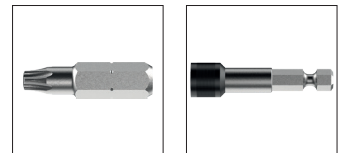

Accessories/Ancillaries

Product code	PU	L	Drive	Head drive	
T25W-25-HEX $\frac{1}{4}$ "	10	25	$\frac{1}{4}$ "	T25W	7662
Bit holder ZA $\frac{1}{4}$ "	1	58		$\frac{1}{4}$ "	

BFS-NUT-5.0

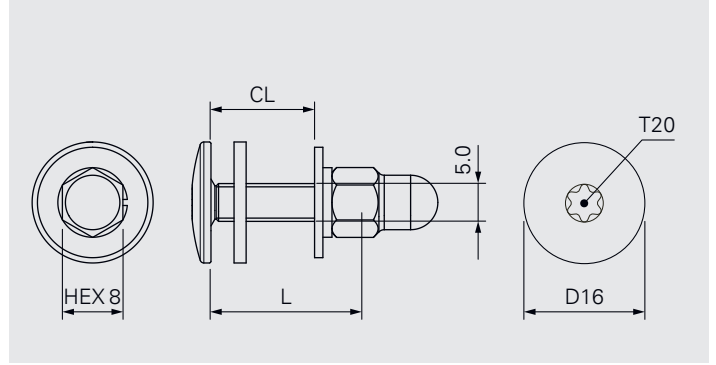
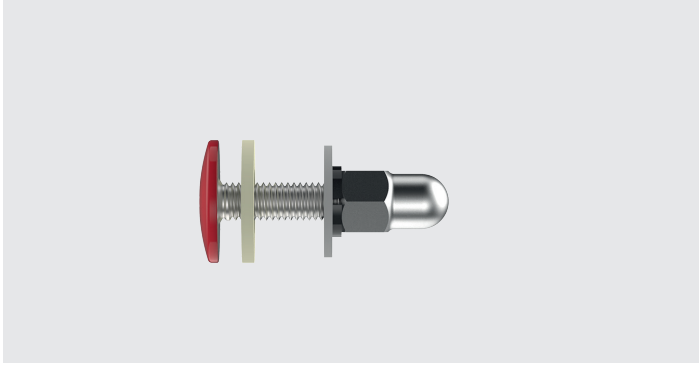

Application

Fastening of cladding panel onto aluminium or steel tube

Component 1 (t₁)

Cladding panel

Component 2 (t₂)

Steel	≥2.0
Aluminium	≥2.0
Pre-drill Ø	5.5

Fastener material

Fastener: Austenitic stainless steel A2

Washer: Plastic

Spring ring: Austenitic stainless steel A4

Cover nut: Austenitic stainless steel A2

Approvals



Features and Benefits

- Aesthetical fixing suitable for installation of balcony panels onto metal tube
- Convenient positioning of the washer from the rearside of the panel thanks to the adhesive washer
- Safety against unwinding of the cover nut given by the steel lock ring and spedcaps® coating
- Wide clamping range given by special cover nut with long threaded part

Documentation

Technical Data

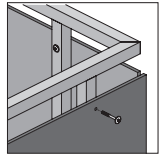

Fastener in A2 onto aluminium and steel

Product code	PU	L	CL	
BFS/7-11-S-D16-M5×20-NUT	100	20	7-11	1389874
BFS/12-16-S-D16-M5×25-NUT		25	12-16	1389878
BFS/17-21-S-D16-M5×30-NUT		30	17-21	1389883
BFS/22-26-S-D16-M5×35-NUT		35	22-26	1389885
BFS/27-31-S-D16-M5×40-NUT		40	27-31	1389892
BFS/32-36-S-D16-M5×45-NUT		45	32-36	1389894
BFS/37-41-S-D16-M5×50-NUT		50	37-41	1389895
BFS/42-46-S-D16-M5×55-NUT		55	42-46	1389896
BFS/47-51-S-D16-M5×60-NUT		60	47-51	1389897
BFS/52-56-S-D16-M5×65-NUT		65	52-56	1389898
BFS/57-61-S-D16-M5×70-NUT		70	57-61	1389899

Installed BFS-NUT

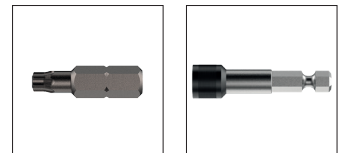
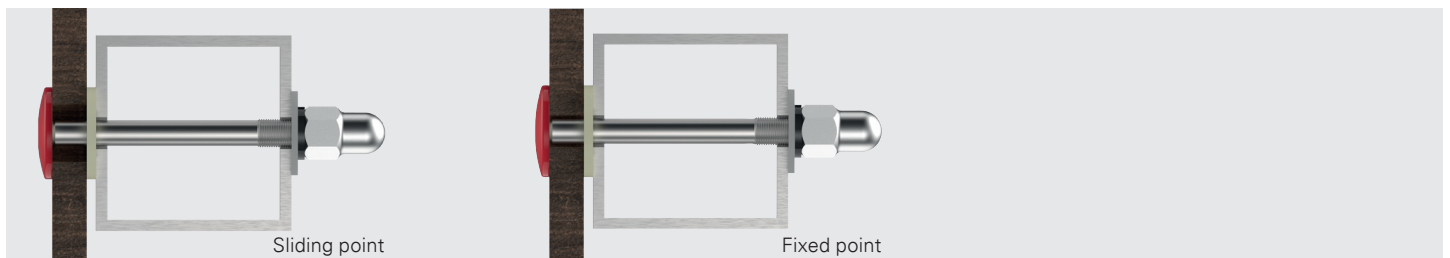

Accessories/Ancillaries

Product code	PU	L	Drive	Head drive	
T20-25-HEX $\frac{1}{4}$ "	10	25	$\frac{1}{4}$ "	T20	769471
Bit holder ZA $\frac{1}{4}$ "	1	58		$\frac{1}{4}$ "	1162306

BFS-SLEEVE-5.0

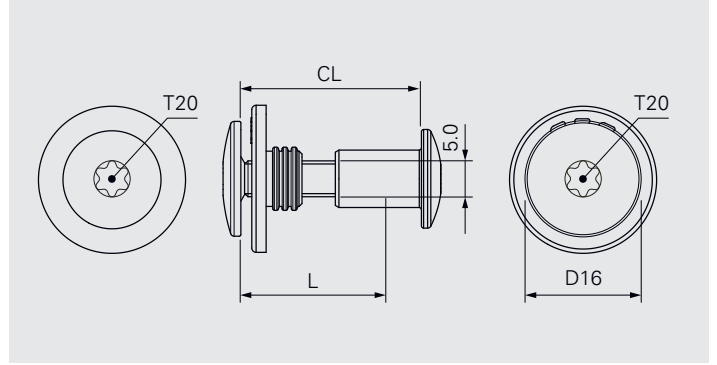
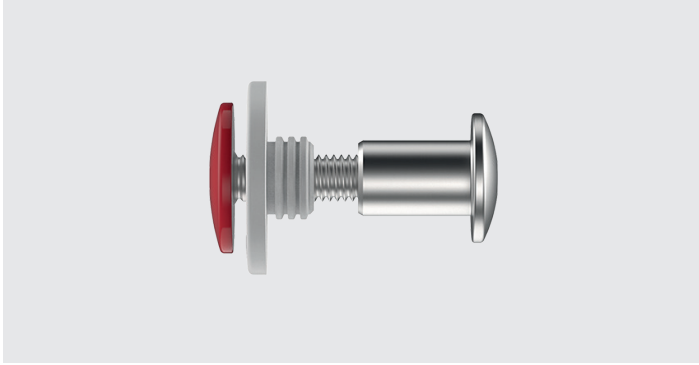

Application

Fastening of cladding panel onto aluminium or steel tube

Component 1 (t₁)

Cladding panel

Component 2 (t₂)

Steel	≥2.0
Aluminium	≥2.0
Pre-drill Ø	8.8

Fastener material

Fastener: Austenitic stainless steel A2

Centering sleeve: Plastic

Cover sleeve: Austenitic stainless steel A2

Approvals



Features and Benefits

- Aesthetical fixing suitable for installation of balcony panels onto metal tube
- Perfect fit of centering sleeve and pre-drilled tube given by ribs
- Safety against unwinding of the threaded sleeve given by the steel lock ring and spedcaps® coating
- Wide clamping range given by special cover sleeve with long threaded part

Documentation

Technical Data

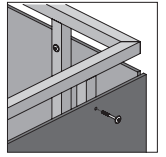

Fastener in A2 onto aluminium and steel

Product code	PU	L	CL	
BFS/21-25-S-D16-M5X20-SLEEVE	100	20	21-25	1395666
BFS/26-30-S-D16-M5X25-SLEEVE		25	26-30	1365671
BFS/31-35-S-D16-M5X30-SLEEVE		30	31-35	1365679
BFS/36-40-S-D16-M5X35-SLEEVE		35	36-40	1395681
BFS/41-45-S-D16-M5X40-SLEEVE		40	41-45	1395682
BFS/46-50-S-D16-M5X45-SLEEVE		45	46-50	1395683
BFS/51-55-S-D16-M5X50-SLEEVE		50	51-55	1395686
BFS/56-60-S-D16-M5X55-SLEEVE		55	56-60	1395687
BFS/61-65-S-D16-M5X60-SLEEVE		60	61-65	1395688
BFS/66-70-S-D16-M5X65-SLEEVE		65	66-70	1395689
BFS/71-75-S-D16-M5X70-SLEEVE		70	71-75	1395690

Installed BFS-SLEEVE

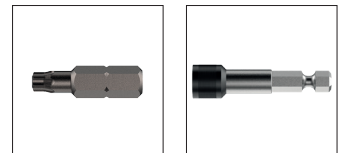
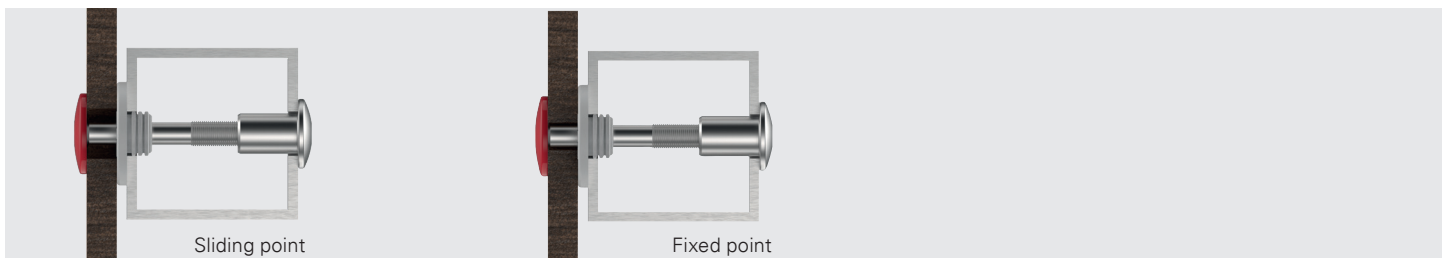

Accessories/Ancillaries

Product code	PU	L	Drive	Head drive	
T20-25-HEX $\frac{1}{4}$ "	10	25	$\frac{1}{4}$ "	T20	769471
Bit holder ZA $\frac{1}{4}$ "	1	58		$\frac{1}{4}$ "	1162306





Accessories

FP Sleeves

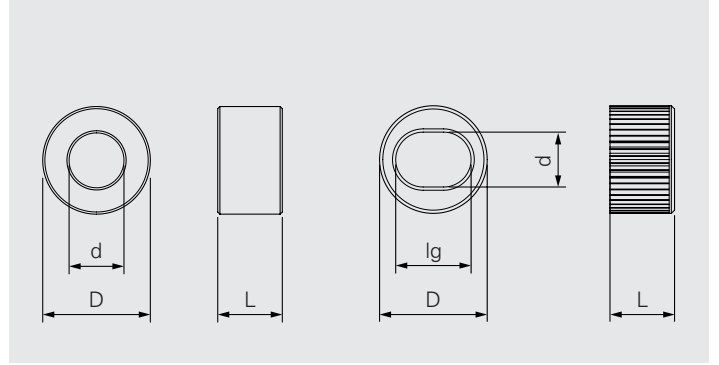
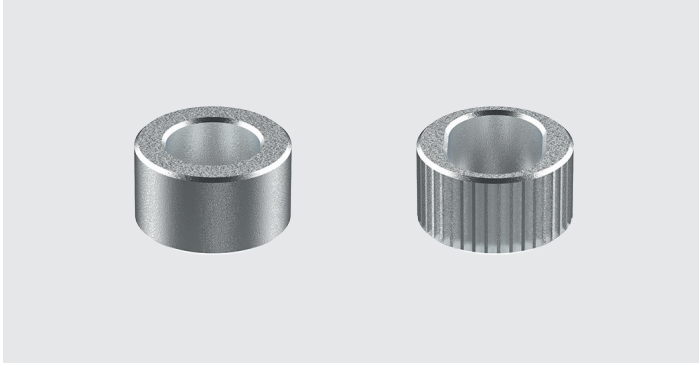

Application

Sleeve to create a fixed point in a pre-drilled cladding panel

Material

A = Aluminium

S = Austenitic stainless steel A2

Installation of a gliding point sleeve

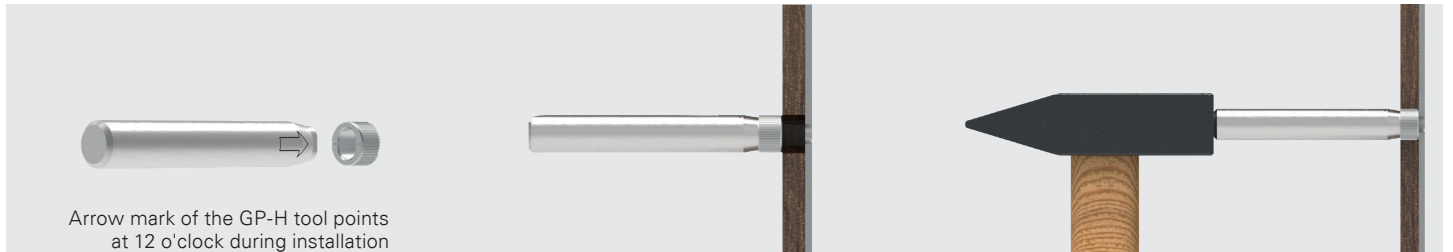

Features and Benefits

- Sleeve suitable for creating a fixed-point in a pre-drilled panel
- Uniform pilot drilling diameter for all pilot holes in a cladding panel
- Fixed point can be defined on-site, therefore very flexible
- Longevity of the fixed-point sleeves as a result of using aluminium or steel

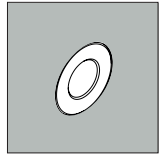

Fixed Point sleeves in Aluminium

Product code	PU	L	D = Pre-drill Ø	d	
FP-A-7,9×6	100	6	8	5.1	1343278
FP-A-8.0×7,5-5,1		7.5			1677475
FP-A-8.0×12-5,1		12			1677477
FP-A-8.5×3,5-5,1		3.5	8.5		1677473
FP-A-8.5×6-5,1		6			1677455
FP-A-8.9×9,5		5.9	9		1547655
FP-A-9,5×3,5-5,1		3.5	9.5		1677480
FP-A-9,5×7,4-5,1		7.4			1677492
FP-A-10,0×6-5,1		6	10		1677458
FP-A-9,9×7,7		7.7			1547652
FP-A-10,0×12-5,1		12			1677478
FP-A-13,0×6-5,1		6	13		1677528

Fixed Point sleeves in A2

Product code	PU	L	D = Pre-drill Ø	d	
FP-S-8,5×6-5,1	100	6	8.5	5.1	1677459
FP-S-9,5×7,4-5,1		7.5	9.5		1677497
FP-S-10,0×6-5,1		12	10		1677498

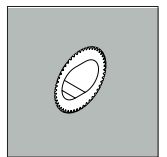

Gliding point sleeves in Aluminium

Product code	PU	L	D = Pre-drill Ø	d	lg	
GP-A-8,0×7,5-5,1	100	7.5	8	5.1	6.2	1677532
GP-A-10,0×6-5.2		6	10	5.2	7.8	1677531

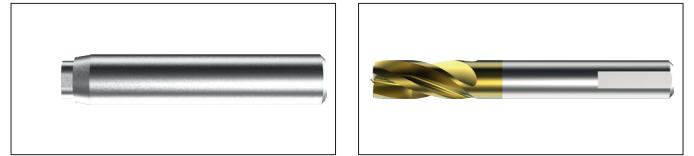

Accessories/Ancillaries

Product code	PU	D	L	
GP-H-8,0	1	8	-	1677534
GP-H-10,0		10		1677533
VHM-8,0×80	1	8	80	1677549
VHM-8,5×80		8.5		1677550
VHM-9,0×80		9		1677559
VHM-9,5×80		9.5		1677581
VHM-10,0×80		10		1677551
VHM-13,0×80		13		1677556

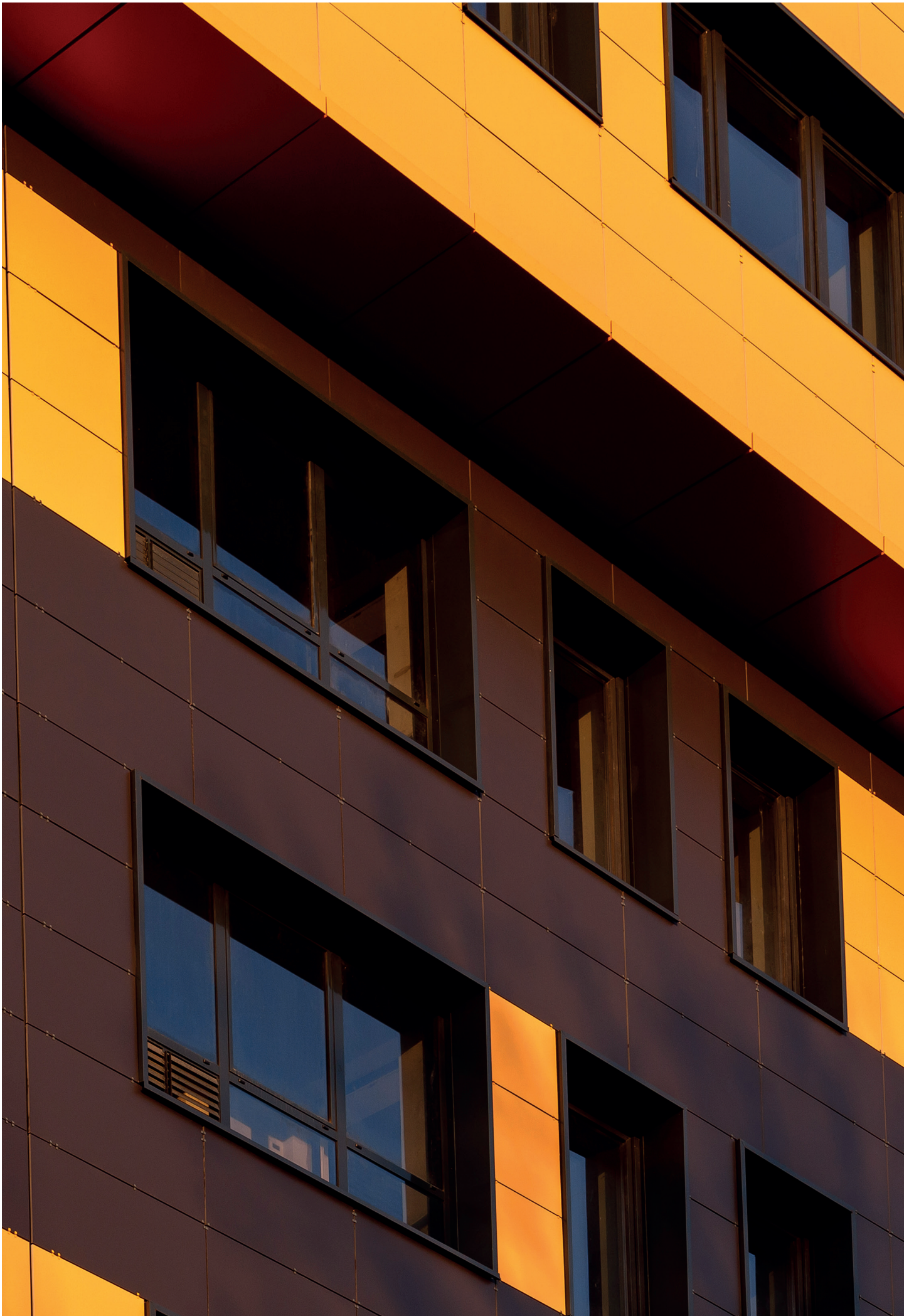

DG

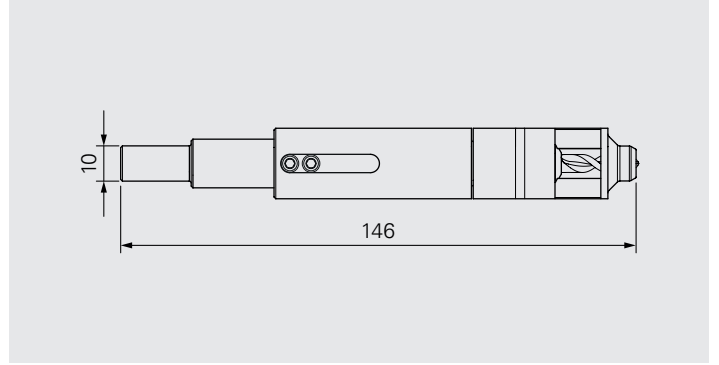

Application

Pre-drilling of a metall subframe concentric to the pre-drilled cladding panel

Use of the DG



Features and Benefits

- Drilling gauge to achieve a hole in the subframe concentric to the pre-drilled panel
- Very convenient installation as a result of working single-handed
- Nosepiece is detached from the rotation
- Variety in use with the cone on the top of every nose piece
- Interchangeable nose piece adapted to the pre-drilled hole diameters of the cladding panel
- Quick and easy change of nose piece and drill bit

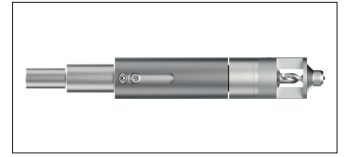

DG complete

Product code	PU	L	Pre-drill Ø panel	Pre-drill Ø subframe	
DG-146×20-7,0	1	146	7-7.9	5.1	1320657
DG-146×20-8,0			8-8.9		1320658
DG-146×20-9,0			9-9.9		1320659
DG-146×20-10,0			10-10.9		1321704

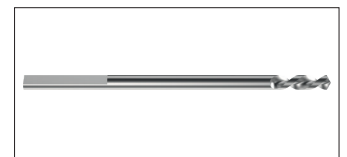
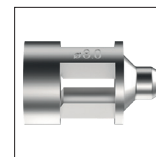

Accessories/Ancillaries

Product code	PU	L	Pre-drill Ø panel	Pre-drill Ø subframe	
Nosepiece DG-7,0	1	-	7-7.9	-	1321195
Nosepiece DG-8,0			8-8.9		1321194
Nosepiece DG-9,0			9-9.9		1321193
Nosepiece DG-10,0			10-10.9		1321190
HSS-DG-4,5×110		110	-	4.5	1573824
HSS-DG-5,1×110				5.1	1257217

Switch of Nosepiece DG

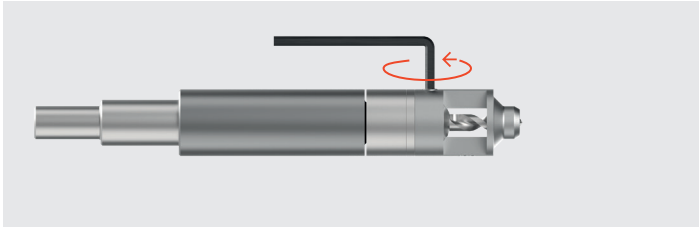

- Slightly loosen the pin with a hex wrench SW2.5

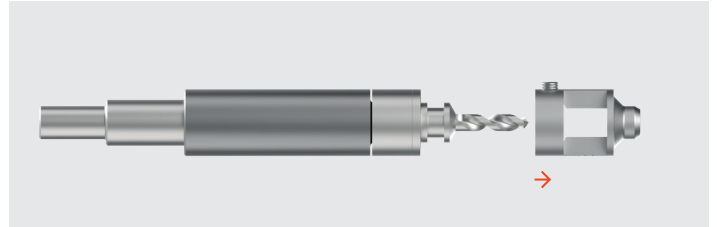

- Remove the Nosepiece DG by pulling it forward

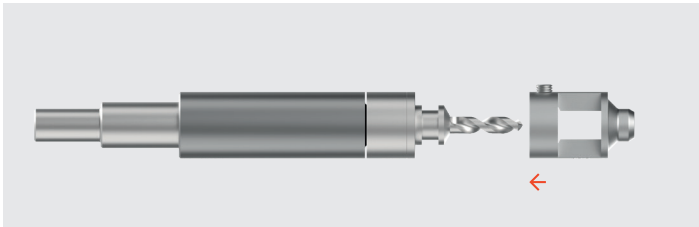

- Push the Nosepiece DG in as far as it will go

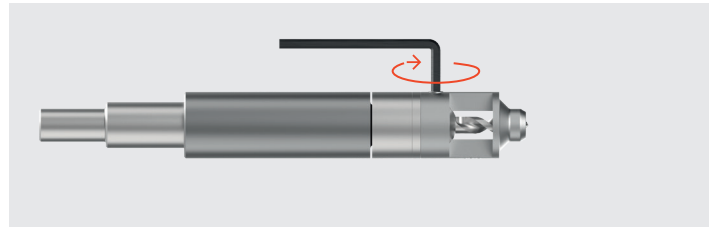

- Tighten the pin to the stop using a hex wrench SW2.5

Switch of the HSS drill

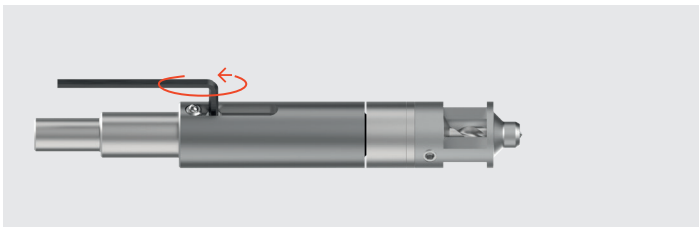

- Completely loosen the pin with a hex wrench SW2.5

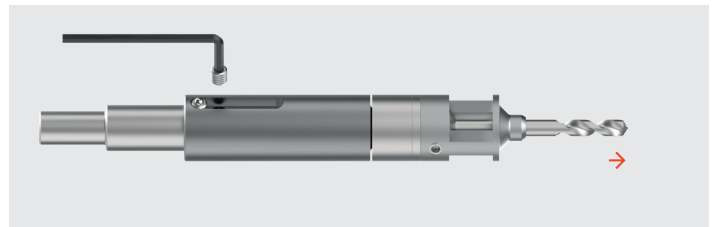

- Pull out the drill

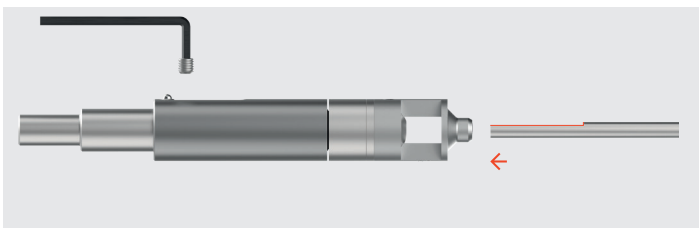

- When inserting the drill bit, make sure that the planar surface of the drill bit points in the direction of the pin



- The HSS drill must be flush with the Nosepiece DG
- Tighten the pin to the stop using a hex wrench SW2.5

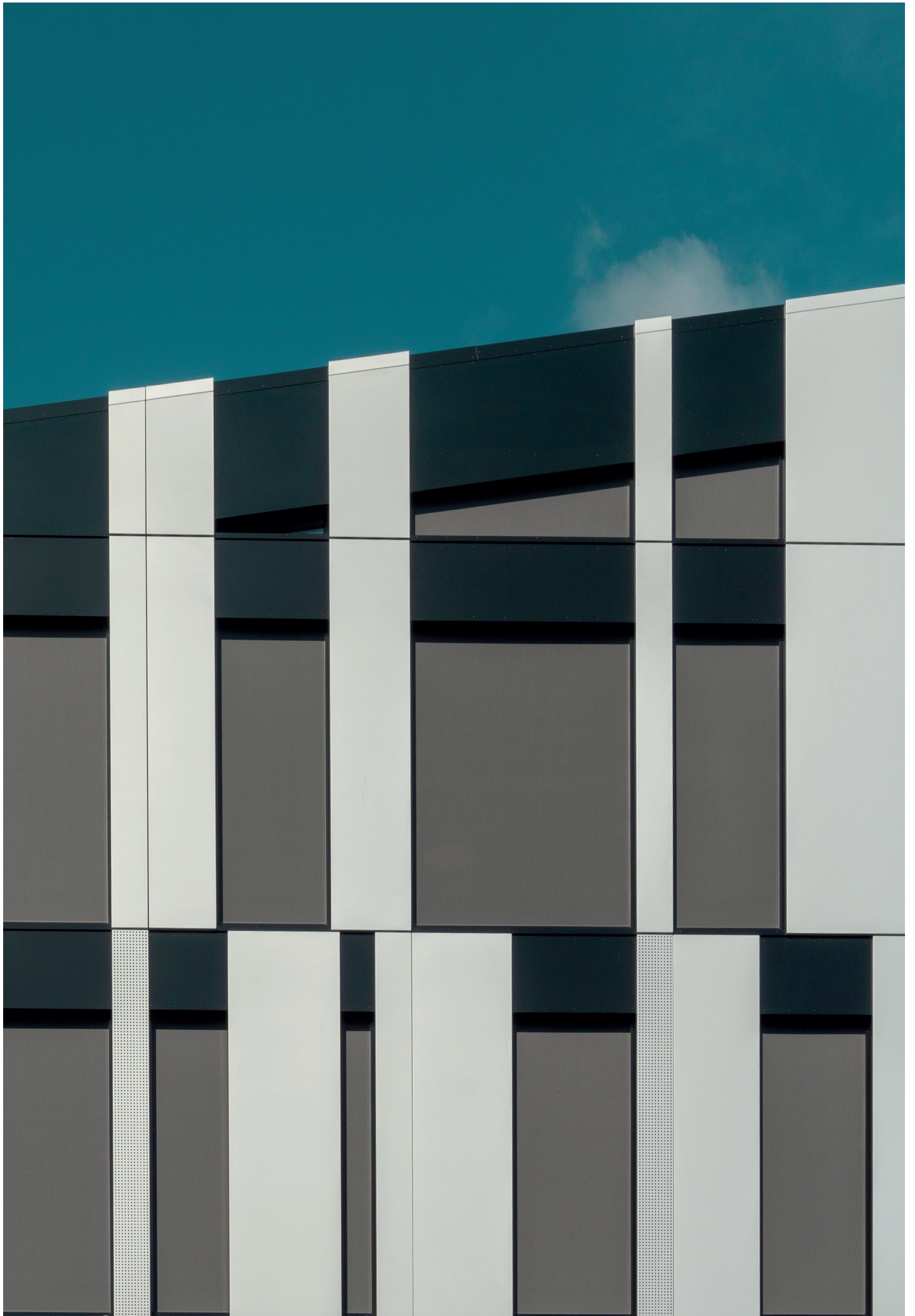

Nosepiece

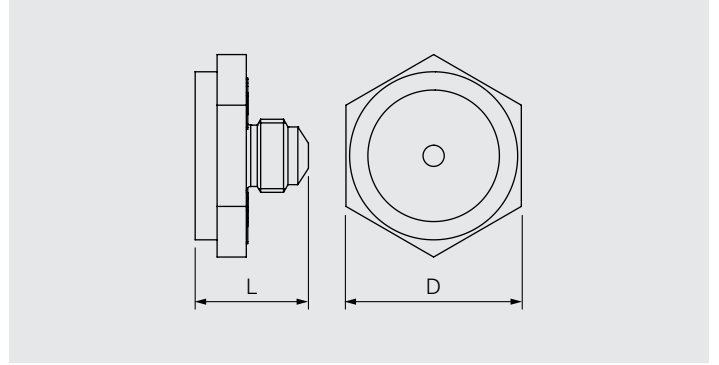
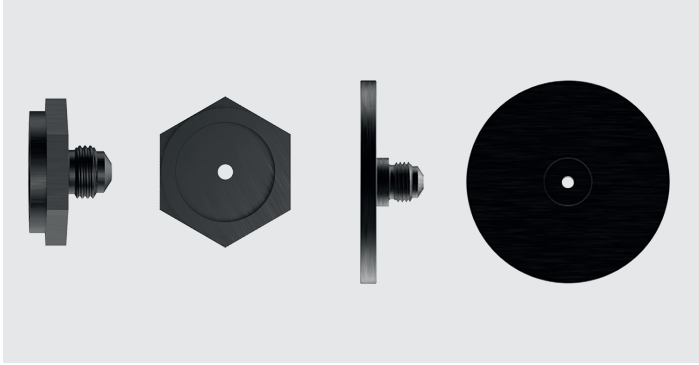

Application

Nosepiece for a correct installation of a rivet

Installation instruction

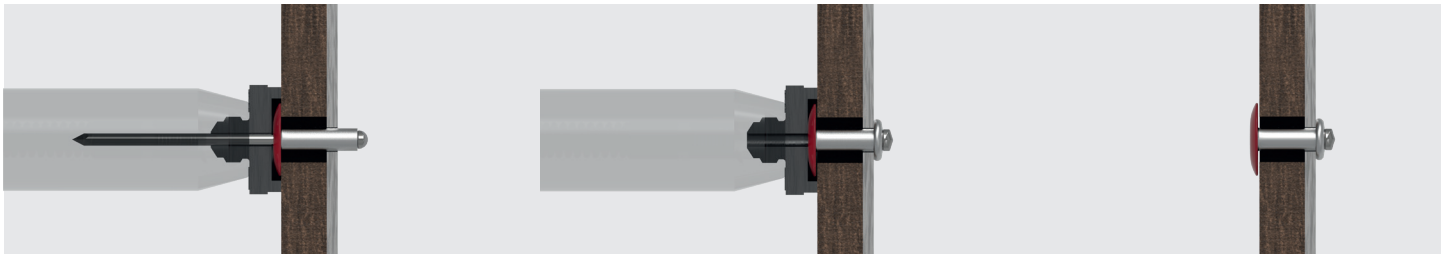

Features and Benefits

- Nosepiece suitable for installation of a rivet
- Ensures a small gap between the rivet-head and the panel surface
- Movement of the panel is possible thanks to the constraint-free installation of the rivet
- Compatible with the AccuBird® and PowerBird® riveting tools from GESIPA®
- Nosepiece in big outer-diameter for use in ACM panels
- Can easily be screwed onto the riveting tool

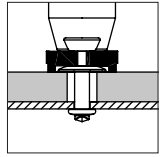

Nosepiece

Product code	PU	L	D	To be used for rivets						
				AP-5.0			ASO-5.0		SSO-5.0	
				D11	D14	D16	D11	D14	D15	
NOSEPIECE-MOVING-POINT AP/ASO	1	15.5	23	✓	✓	✓	✓	✓	✗	974620
NOSEPIECE-MOVING-POINT-SSO-D15-50xL			30	✗	✗	✗	✗	✗	✓	1291200

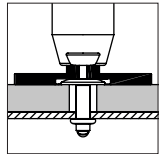

Nosepiece for Aluminium composite panels

Product code	PU	L	D	To be used for rivets					
				AP-5.0			ASO-5.0		
				D11	D14	D16	D11	D14	
NOSEPIECE-MOVING-PT-AP11/ASO-D11-COMP	1	15.5	50	✓	✗	✗	✓	✗	1429523
NOSEPIECE-MOVING-PT-AP14/ASO-D14-COMP				✗	✓	✗	✗	✓	1414585
NOSEPIECE-MOVING-PT-AP16-COMP				✗	✗	✓	✗	✗	1429551

Depth locator

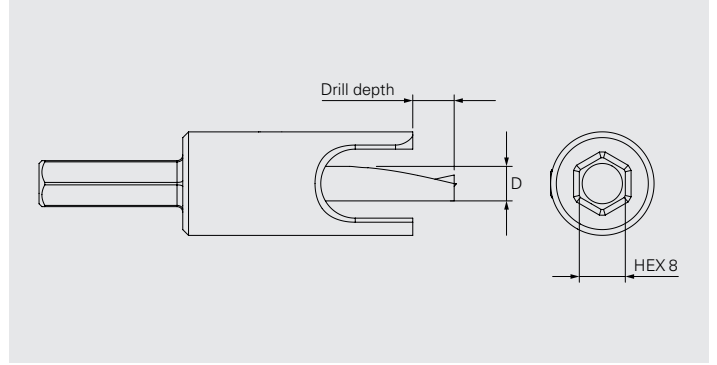
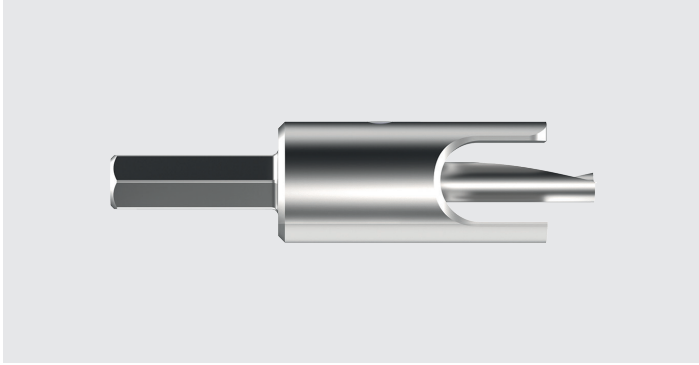

Application

Depth locator and drill bits for a correct blind hole

Life expectancy of the drills

	in HPL	in Fibrecement
VHM-6.0	500 drills	500 drills
HSS-4.9	200 drills	–

Recommended rotation-speed max. 1500–1800 rpm

Installation instruction



Features and Benefits

- Depth locator and corresponding drill bits to create a correct blind hole
- Defined drill depth, no adjustment needed
- Drill bit can easily be exchanged

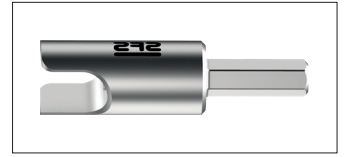

Depth locator

Product code	PU	
Depth locator for drill bit universal	1	1478567

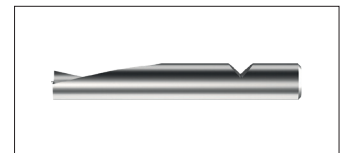

Drill bits

Product code	PU	L	Drill depth	D	
VHM-6,0x40	1	40	5	6	1615070
VHM-6,0x40,5		40.5	5.5		1586737
VHM-6,0x41		41	6		1615072
VHM-6,0x41,5		41.5	6.5		1615073
VHM-6,0x42		42	7		1615074
VHM-6,0x42,5		42.5	7.5		1615075
VHM-6,0x43		43	8		1615077
VHM-6,0x43,5		43.5	8.5		1615078
VHM-6,0x45		45	10		1479984
HSS-4,9x40,5		1	40.5		5.5
HSS-4,9x42,5	42.5		7.5	1586913	
HSS-4,9x45,5	45.5		10.5	1586914	

Switch of the drill bit

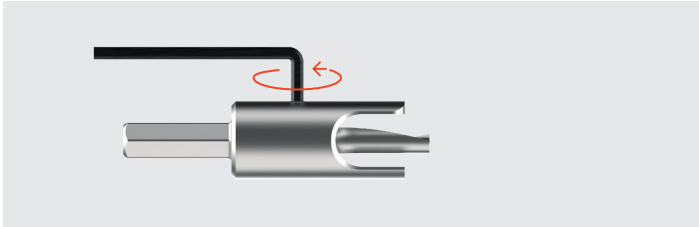

- Slightly loosen the pin with a hex wrench SW2.5

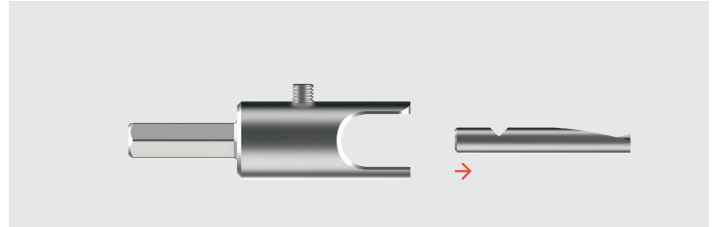

- Remove the drill bit by pulling it forward

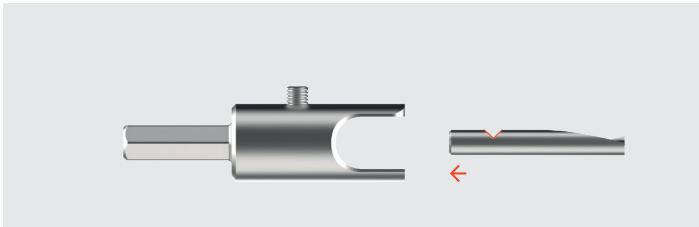

- When insertig the drill bit, make sure that the notch of the drill bit points in the direction of the pin

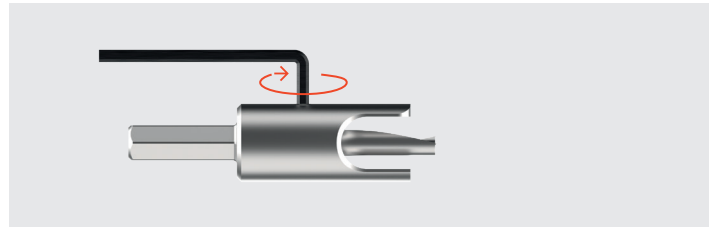

- Tighten the pin to the stop using a hex wrench SW2.5

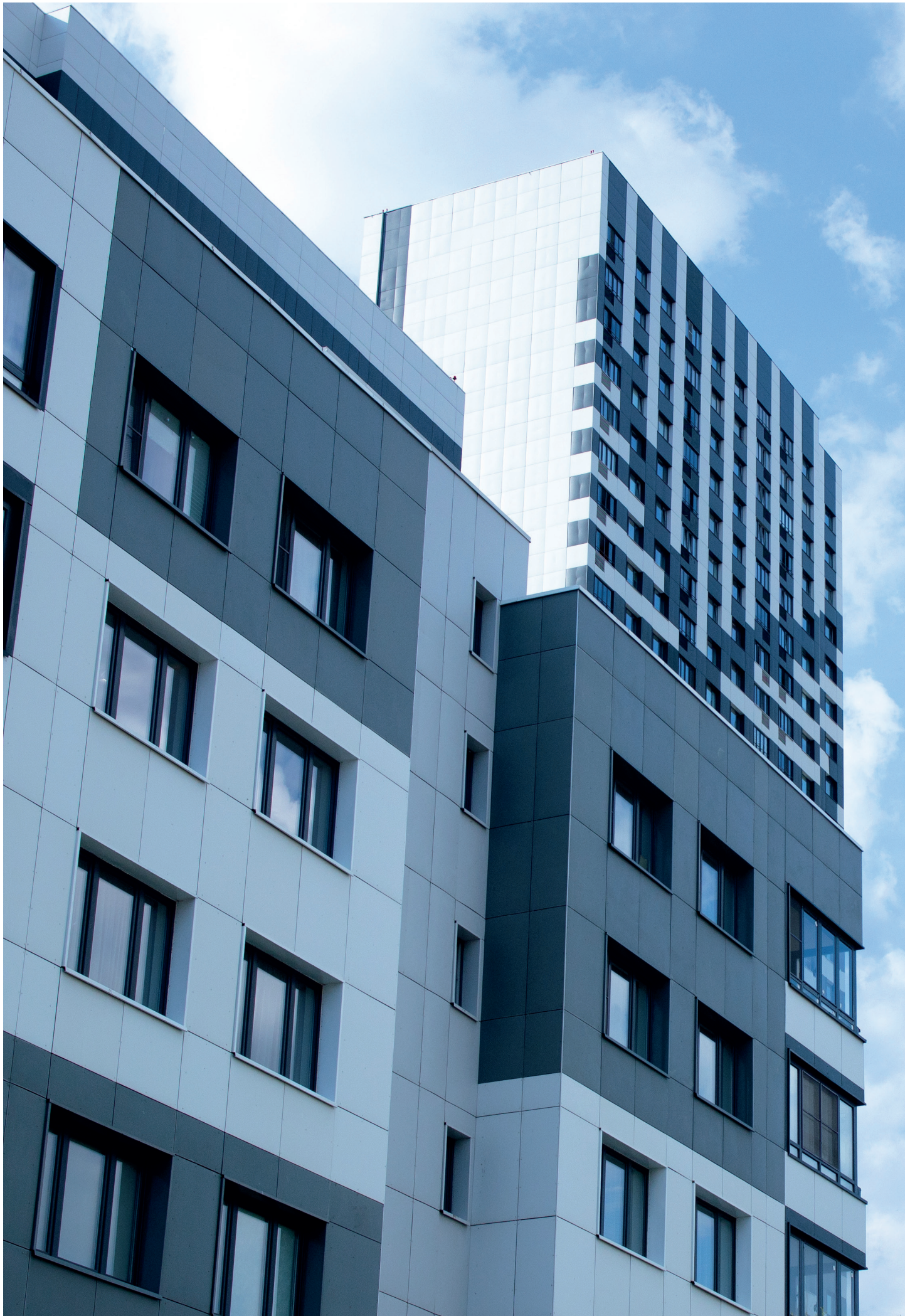

EPDM-Tape



Technical characteristics

Building material class DIN 4102	B2 (normal flammable)
Fire classification EN 13501-1	Class E
Water vapour resistance factor	32'000 μ
Temperature resistance	-30°C up to +80°C
UV resistance	24 months
Elongation	250%
Storage temperature	+5°C up to +25°C
Storage time	2 years

Application

Sealing tape to protect the timber batten against humidity

Material

Elastomer sheet made of black EPDM rubber

Features and Benefits

- High resistance to mechanical damage
- Excellent movement capability in both transverse and longitudinal direction
- High ageing resistance
- Solvent free

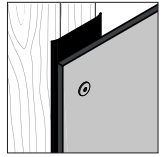

Sealing tape EPDM

Product code	PU	Wide tape (mm)	Thickness tape (mm)	Roll length (m)	
EPDM-TAPE-0,75×60×25000	1	60	0.75	25	1122506
EPDM-TAPE-0,75×80×25000		80			1193862
EPDM-TAPE-0,75×100×25000		100			1122504
EPDM-TAPE-0,75×120×25000		120			1288745

Sealing tape EPDM self adhesive on one side

Product code	PU	Wide tape (mm)	Thickness tape (mm)	Roll length (m)	
EPDM-TAPE-ADHESIVE-0,75×60×25000	1	60	0.75	25	1122507
EPDM-TAPE-ADHESIVE-0,75×100×25000		100			1122508
EPDM-TAPE-ADHESIVE-0,75×120×25000		120			1329007

SDS drill bits

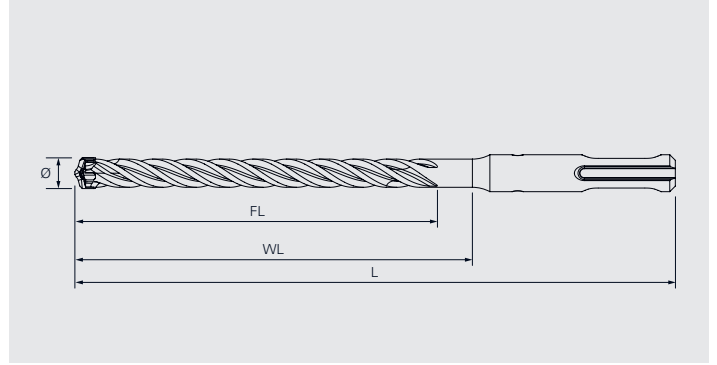

Application

Pre-drill of reinforced concrete or natural stone

Approvals



Material

4x carbide cutting edge, steel shank

Features and Benefits

- Four symmetrical cutting edges for exact drilling diameters
- No slipping on the surface due to the centering tip
- Optimal removing of drilling dust due to the cupping flute geometry
- Optimum drilling performance and no seizure when hitting reinforcing steel thanks to the patented reinforcement chamfer
- 50% longer service life due to special geometry

SDS drill bits

Product code	PU	D	L	WL	FL	
SDS-6×215/150-4C	1	6	215	150	150	1487583
SDS-6×315/250-4C			315	250	250	1487584
SDS-6×515/455-4C			515	455	200	1608141
SDS-8×215/150-4C	1	8	215	150	150	1487585
SDS-10×215/150-4C		10				1487586

Bits, sockets and drive bars



Bit holder and different T-drives

Product code	PU	Drive	Head drive	L			
Bit holder ZA1/4"	1	1/4"	1/4"	58	1162306		
T20-25-HEX1/4"	10	1/4"	T20	25	769471		
T20W-25-HEX1/4"	1		T20W		895280		
T25W-25-HEX1/4"			T25W*		7662		
T25P-25-HEX1/4"	10		T25P**		1658024		
T30-25-HEX1/4"			T30		24010		
T40-25-HEX1/4"			T40		769474		
HD20-25mm			HD-20		1205164		
SR2-25-HEX1/4"			SR2		1146918		
T30-40-1/2"		1/2"	T30	40	1489154		
T40-40-1/2"			T40		1489155		
E308-1/4"-50	1	1/4"	HEX8	50	1646160		
E313-1/4"-50			HEX13		508029		
E420-1/4"-74			L12	74	973316		
E508-1/2"-40		1/2"	HEX8	40	1648380		
E513-1/2"-78			HEX13	78	1649258		
HECO-ClicFix		1/4"	1/4"	10	1205057		

*W-Bit for wet painted fasteners | **P-Bit for powder painted fasteners

